

REVISION HISTORY				
REV.	DESCRIPTION	DATE	ECO	BY
A	2014 POLYMER DIG BOOK	01/07/14	NONE	THARKENRIDER
B	UPDATED TAG DATA TO INCLUDE COPING LENGTHS.	1/26/2015	391702	JBOSSERDET

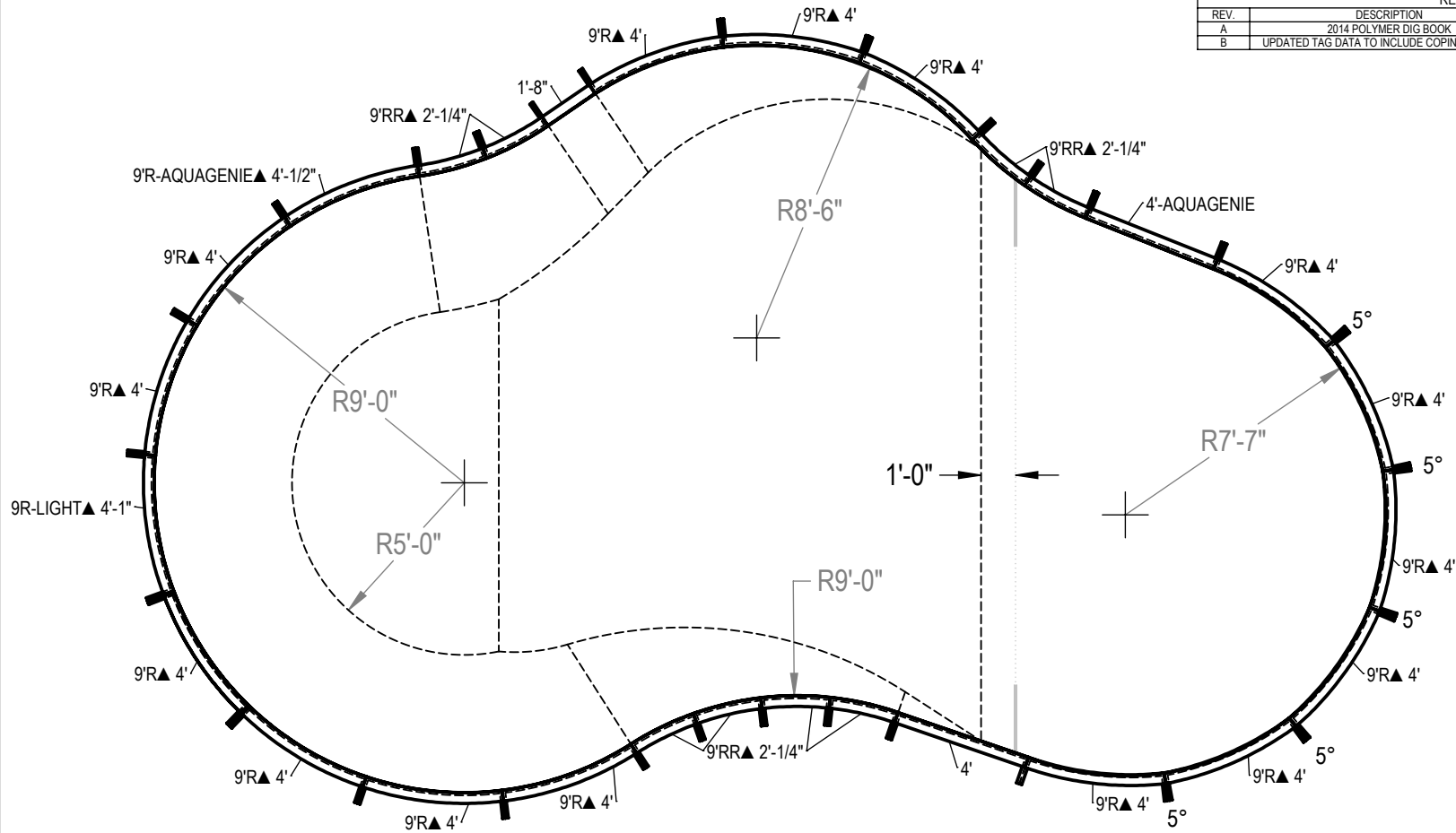

ITEM	FILE NAME	DESCRIPTION	CUSTOMER DRAWING #	VENDOR PART #	QTY.	VENDOR NAME	MATERIAL
1	BRACE	BRACE, 5 TAB, TRANQUILITY - 500 SERIES	HP599	HP599	28	HYDRA POOLS	PS
2	INSERT, 5° WEDGE	INSERT, 5° WEDGE	HP226	HP226	5	HYDRA POOLS, IA	PP Homopolymer
3	PANEL, 1'-8 IN LONG	PANEL, 1'-8" LONG - 500 SERIES	HP516	HP516	1	HYDRA POOLS	PS
4	PANEL, 4' LONG	PANEL, 4' LONG - 500 SERIES	HP504	HP504	1	HYDRA POOLS	PS
5	PANEL, 4' LONG WITH AQUA GENIE	PANEL, 4' LONG WITH AQUA GENIE - 500 SERIES	HP504A	HP504A	1	HYDRA POOLS	PS
6	PANEL, 9' RADIUS WITH AQUA GENIE	PANEL, 9' RADIUS WITH AQUAGENIE - 500 SERIES	HP559A	HP559A	1	HYDRA POOLS	PS
7	PANEL, 9' RADIUS WITH LIGHT	PANEL, 9' RADIUS WITH LIGHT - 500 SERIES	HP559LL	HP559LL	1	HYDRA POOLS	PS
8	PANEL, 9' RADIUS, 4' LONG	PANEL, 9' RADIUS, 4' LONG - 500 SERIES	HP559	HP559	16	HYDRA POOLS	PS
9	PANEL, 9' REVERSE RADIUS	PANEL, 9' REVERSE RADIUS - 500 SERIES	HP519N	HP519N	8	HYDRA POOLS	PS

- NOTES:**
- THESE ARE FINISHED DIMENSIONS READY FOR THE LINER.
  - DIMENSIONS ARE FROM INSIDE POOL PANELS.
  - THE IDEAL WATER LEVEL SHOULD BE TO THE MIDDLE OF THE SKIMMER OPENING(S).
- EXCAVATION NOTES:**
- ROUGH EXCAVATION SHOULD BE 2" DEEPER IN EACH INSTANCE.
  - SOIL TO HAVE MINIMUM BEARING CAPACITY OF 1500 PSF.
  - LOCATE TOP OF POOL AT LEAST 6" ABOVE THE SURROUNDING LAND ELEVATION.
  - SEE "OVER DIG DETAIL" FOR EXCAVATION AROUND POOL.
  - FILL VOIDS UNDER BASE OF PANELS AND TAMP WELL.
  - BACK FILL WITH NON-EXPANSIVE MATERIAL.
  - ANSI / APSP / ICC-5 FOR RESIDENTIAL POOLS, 2003-2007 BOCA CODE SECTION 421.
- IMPORTANT NOTES:**
- THIS DOCUMENT IS FOR ILLUSTRATIVE PURPOSES ONLY. THE DEALER OR CONTRACTOR WHO SELLS OR INSTALLS YOUR POOL IS AN INDEPENDENT CONTRACTOR AND IS NOT AN AGENT OF THE MANUFACTURER. THE CONSTRUCTION METHODS ILLUSTRATED HERE ARE SUGGESTIONS AND APPLY ONLY TO NORMAL GROUND CONDITIONS. THERE MAY BE ADDITIONAL PRECAUTIONS AND/OR METHODS OF CONSTRUCTION. PROPER INSTALLATION IS THE RESPONSIBILITY OF THE DEALER/BUILDER/CONTRACTOR.

ENGINEERING DRAWING NUMBER: <b>00005037</b>	WEIGHT:	<b>UNLESS OTHERWISE SPECIFIED</b> DIMENSIONS ARE IN INCHES TOLERANCES DECIMALS: X ± .1 XX ± .01 XXX ± .001 XXXX ± .0005	DESIGNED BY:	CREATION DATE:	<b>HYDRA POOLS</b>
	lbs		RCOLBOCH	6/10/2013	
	VOLUME:		DETAILED BY:	DETAILED DATE:	
	Inch <sup>3</sup>		JBOSSERDET	10/5/2012	
COLOR:	ANGULAR: X ± 0.5	LAST REVISED BY:	LAST REVISED DATE:	TITLE:	LAYOUT, 21'-8" X 35'-9", LAGOON, LEFT, 8' DEEP, 500 SERIES
NA	THIRD ANGLE PROJECTION	Jbosserdet	1/26/2015	PART NUMBER:	
HEAT TREAT:		MATERIAL:			<b>50929</b>
NA					SCALE: 1:192
FINISH:					SHEET: 1 OF 6
TEXTURE:					<b>A</b>
NA					

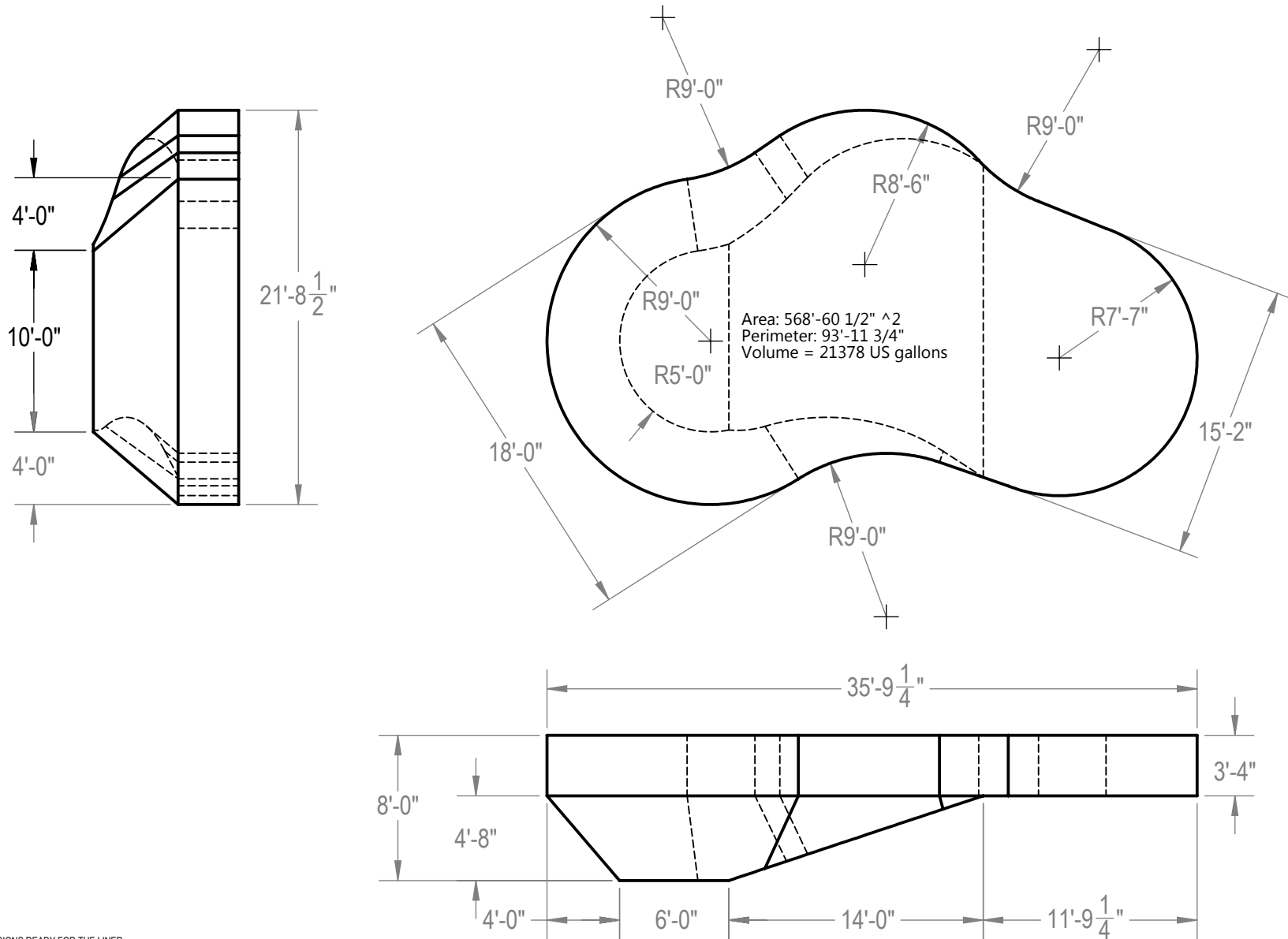

**NOTES:**

1. THESE ARE FINISHED DIMENSIONS READY FOR THE LINER.
2. DIMENSIONS ARE FROM INSIDE POOL PANELS.
3. THE IDEAL WATER LEVER SHOULD BE TO THE MIDDLE OF THE SKIMMER OPENING(S).

**EXCAVATION NOTES:**

4. ROUGH EXCAVATION SHOULD BE 2" DEEPER IN EACH INSTANCE.
5. SOIL TO HAVE MINIMUM BEARING CAPACITY OF 1500 PSF.
6. LOCATE TOP OF POOL AT LEAST 6" ABOVE THE SURROUNDING LAND ELEVATION.
7. SEE "OVER DIG DETAIL" FOR EXCAVATION AROUND POOL.
8. FILL VOIDS UNDER BASE OF PANELS AND TAMP WELL.
9. BACK FILL WITH NON-EXPANSIVE MATERIAL.
10. ANSI / APSP / ICC-5 FOR RESIDENTIAL POOLS, 2003-2007 BOCA CODE SECTION 421.

**IMPORTANT NOTES:**

11. THIS DOCUMENT IS FOR ILLUSTRATIVE PURPOSES ONLY. THE DEALER OR CONTRACTOR WHO SELLS OR INSTALLS YOUR POOL IS AN INDEPENDENT CONTRACTOR AND IS NOT AN AGENT OF THE MANUFACTURER. THE CONSTRUCTION METHODS ILLUSTRATED HERE ARE SUGGESTIONS AND APPLY ONLY TO NORMAL GROUND CONDITIONS. THERE MAY BE ADDITIONAL PRECAUTIONS AND/OR METHODS OF CONSTRUCTION. PROPER INSTALLATION IS THE RESPONSIBILITY OF THE DEALER/BUILDER/CONTRACTOR.

ENGINEERING DRAWING NUMBER: <b>00005037</b>	WEIGHT:	<b>UNLESS OTHERWISE SPECIFIED</b> DIMENSIONS ARE IN INCHES TOLERANCES DECIMALS: X ± .1 XX ± .01 XXX ± .001 XXXX ± .0005  ANGULAR: X ± 0.5 THIRD ANGLE PROJECTION	DESIGNED BY:	RCOLBOCH	CREATION DATE:	6/10/2013	<b>HYDRA POOLS</b>		
	VOLUME:		Detailed by:	JBOSSERDET	Detailed Date:	10/5/2012			
	Inch <sup>3</sup>		COLOR:	LAST REVISED BY:	jbosserdet	LAST REVISED DATE:	1/26/2015	TITLE:	LAYOUT, 21'-8" X 35'-9", LAGOON, LEFT, 8' DEEP, 500 SERIES
	NA		HEAT TREAT:	MATERIAL:				PART NUMBER:	50929
NA	FINISH:					SCALE:	1:192	A	
NA	TEXTURE:					SHEET:	2 OF 6		

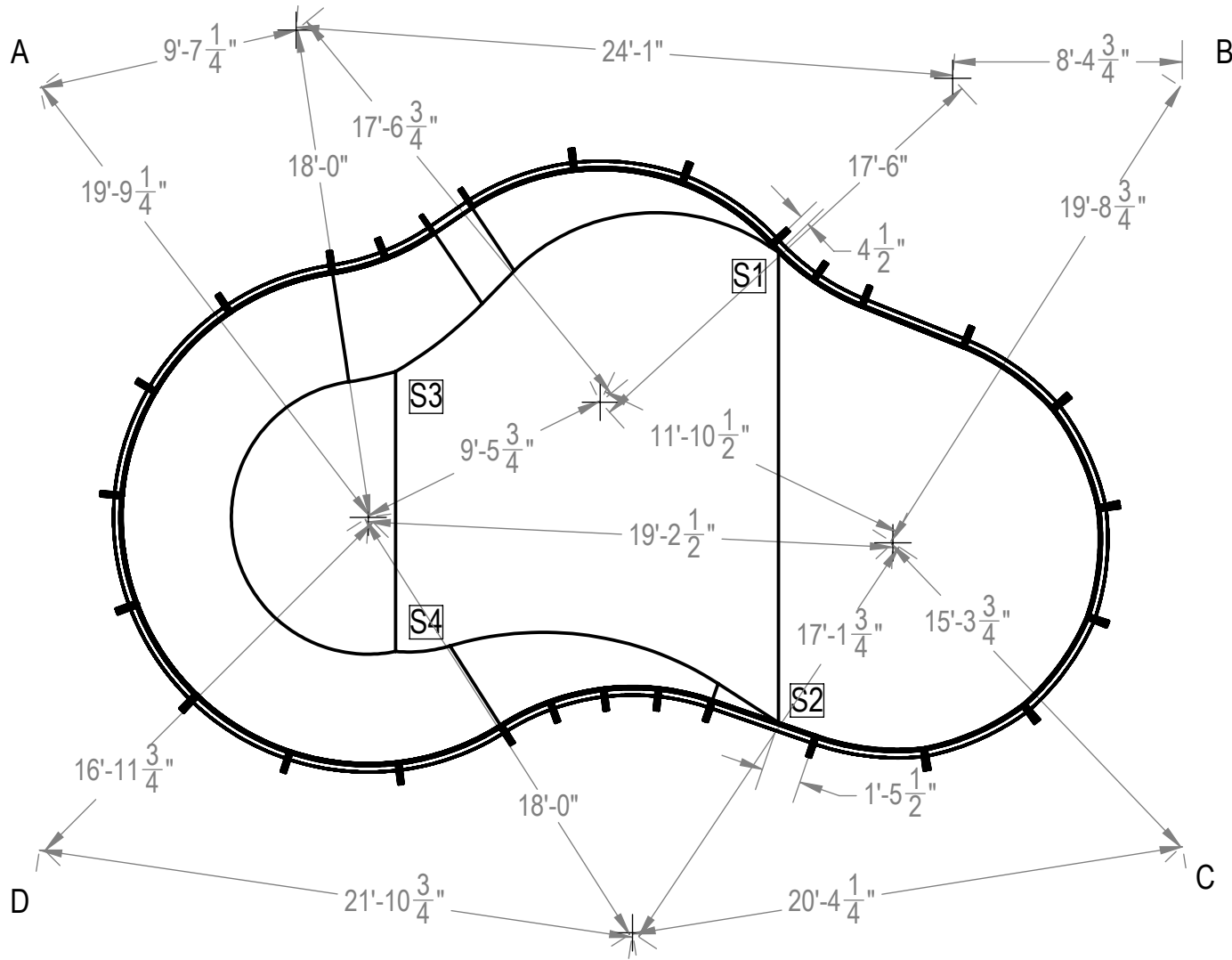

A-S1	27'-8"
B-S1	15'-11 1/2"
A-S2	35'-7 1/4"
B-S2	27'-6"
A-S3	16'-7 3/4"
B-S3	30'-7"
A-S4	24'-4 1/2"
B-S4	35'-4 3/4"

ENGINEERING DRAWING NUMBER: <b>00005037</b>	WEIGHT:	<b>UNLESS OTHERWISE SPECIFIED</b> DIMENSIONS ARE IN INCHES TOLERANCES DECIMALS: X ± 0.1 XX ± 0.01 XXX ± 0.005 XXXX ± 0.0005 ANGULAR: X ± 0.5 THIRD ANGLE PROJECTION 	DESIGNED BY:	CREATION DATE:	<b>HYDRA POOLS</b>  TITLE: LAYOUT, 21'-8" X 35'-9", LAGOON, LEFT, 8' DEEP, 500 SERIES  PART NUMBER: <b>50929</b>	
	lbs		RCOLBOCH	6/10/2013		
	VOLUME:		DETAILED BY:	DETAILED DATE:		
	Inch <sup>3</sup>		JBOSSERDET	10/5/2012		
	COLOR:		LAST REVISED BY:	LAST REVISED DATE:		
	NA		jbosserdet	1/26/2015		
HEAT TREAT:	MATERIAL:					
NA					SCALE: 1:192	SIZE: A
FINISH:					SHEET: 3 OF 6	
TEXTURE:						
NA						

	A	B	C	D
1	15'-2 3/4"	41'-6"	40'-9 1/2"	13'-1 3/4"
2	11'-11"	39'-1 3/4"	41'- 1/4"	17'-1 1/4"
3	10'-9 1/2"	35'-9 1/4"	39'-10 1/2"	20'-8"
4	12'-8 1/4"	31'-9 3/4"	37'-5 1/4"	23'-5 3/4"
5	14'-1 1/2"	29'-9 1/2"	36'-1 3/4"	24'-10 1/2"
6	15'-4 3/4"	27'-10 1/4"	35'-3 3/4"	26'-7 1/2"
7	16'-5"	26'-4"	34'-10 3/4"	28'-1 3/4"
8	19'-9 1/4"	22'-5 1/4"	33'-2 1/2"	31'-5 1/2"
9	23'-8 3/4"	18'-7 1/2"	30'-4"	33'-8 1/2"
10	27'-4 1/4"	16'-1"	26'-7 1/4"	34'-7 1/4"
11	29'-1 3/4"	15'-3"	24'-8"	35'-0"
12	31'-1"	14'-2 1/2"	22'-11"	35'-11"
13	35'- 3/4"	12'-5 1/4"	19'-10 3/4"	38'-4 1/4"
14	38'-10"	12'-8 1/2"	16'-7 1/2"	40'-3 1/2"
15	41'-7 1/4"	15'-8 1/4"	12'-8 1/2"	40'-7"
16	42'-10 1/2"	19'-7 3/4"	9'-1"	39'-2 1/4"
17	42'-5 1/4"	23'-3 1/4"	7'-9 1/2"	36'-3 3/4"
18	40'-4"	25'-11"	10'-1 1/4"	32'-6 1/4"
19	36'-11 1/2"	27'-2 1/2"	13'-11 3/4"	28'-8"
20	33'-3"	28'-2 1/2"	17'-11 3/4"	25'-2"
21	31'-6 1/4"	29'-1 1/2"	20'-0"	23'-4 1/4"
22	30'-1 1/4"	30'-6"	21'-11 1/4"	21'-4 3/4"
23	29'-1 3/4"	32'-2 1/2"	23'-8 3/4"	19'-4 1/2"
24	28'-9"	34'-1 1/2"	25'-4"	17'-4 3/4"
25	27'-11"	37'-9 3/4"	28'-10"	13'-5 1/2"
26	25'-11"	40'-7 3/4"	32'-9 1/2"	9'-9 1/2"
27	22'-10 3/4"	42'-3 3/4"	36'-5 1/2"	7'-11 3/4"
28	19'-2 1/4"	42'-7 1/4"	39'-2 3/4"	9'-6 1/2"

A-B	41'-9 1/4"
B-C	27'-8 1/2"
A-C	50'-1 1/2"

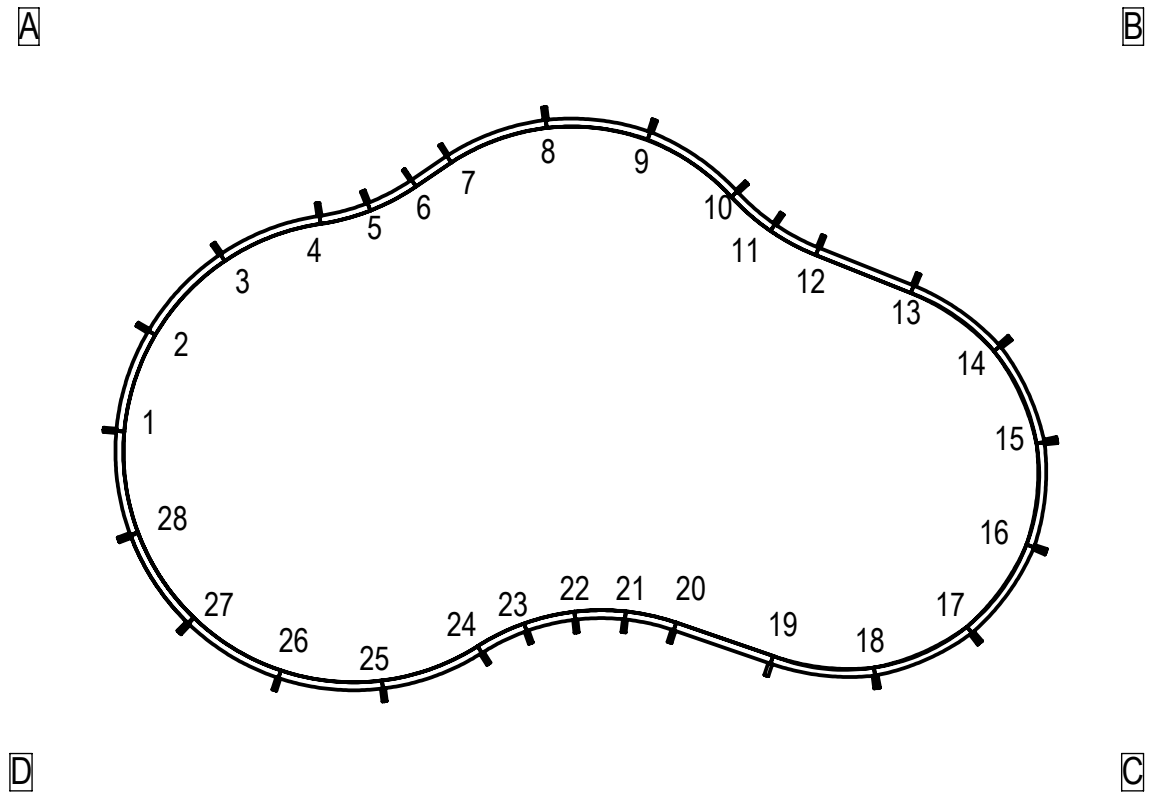

ENGINEERING DRAWING NUMBER:  
00005037

WEIGHT:	<b>UNLESS OTHERWISE SPECIFIED</b> DIMENSIONS ARE IN INCHES TOLERANCES DECIMALS: X ± 0.1 XX ± 0.01 XXX ± 0.005 XXXX ± 0.0005  ANGULAR: X ± 0.5 THIRD ANGLE PROJECTION
lbs	
VOLUME:	
Inch <sup>3</sup>	
COLOR:	
HEAT TREAT:	
FINISH:	
TEXTURE:	
NA	
NA	

DESIGNED BY:	RCOLBOCH
CREATION DATE:	6/10/2013
DETAILED BY:	JBOSSERDET
DETAILED DATE:	10/5/2012
LAST REVISED BY:	jbosserdet
LAST REVISED DATE:	1/26/2015
MATERIAL:	

<b>HYDRA POOLS</b>	
TITLE: LAYOUT, 21'-8" X 35'-9", LAGOON, LEFT, 8' DEEP, 500 SERIES	
PART NUMBER:	<b>50929</b>
SCALE:	1:192
SHEET:	4 OF 6
SIZE:	<b>A</b>

A  
 15'-8 1/2"  
 12'-0"  
 D

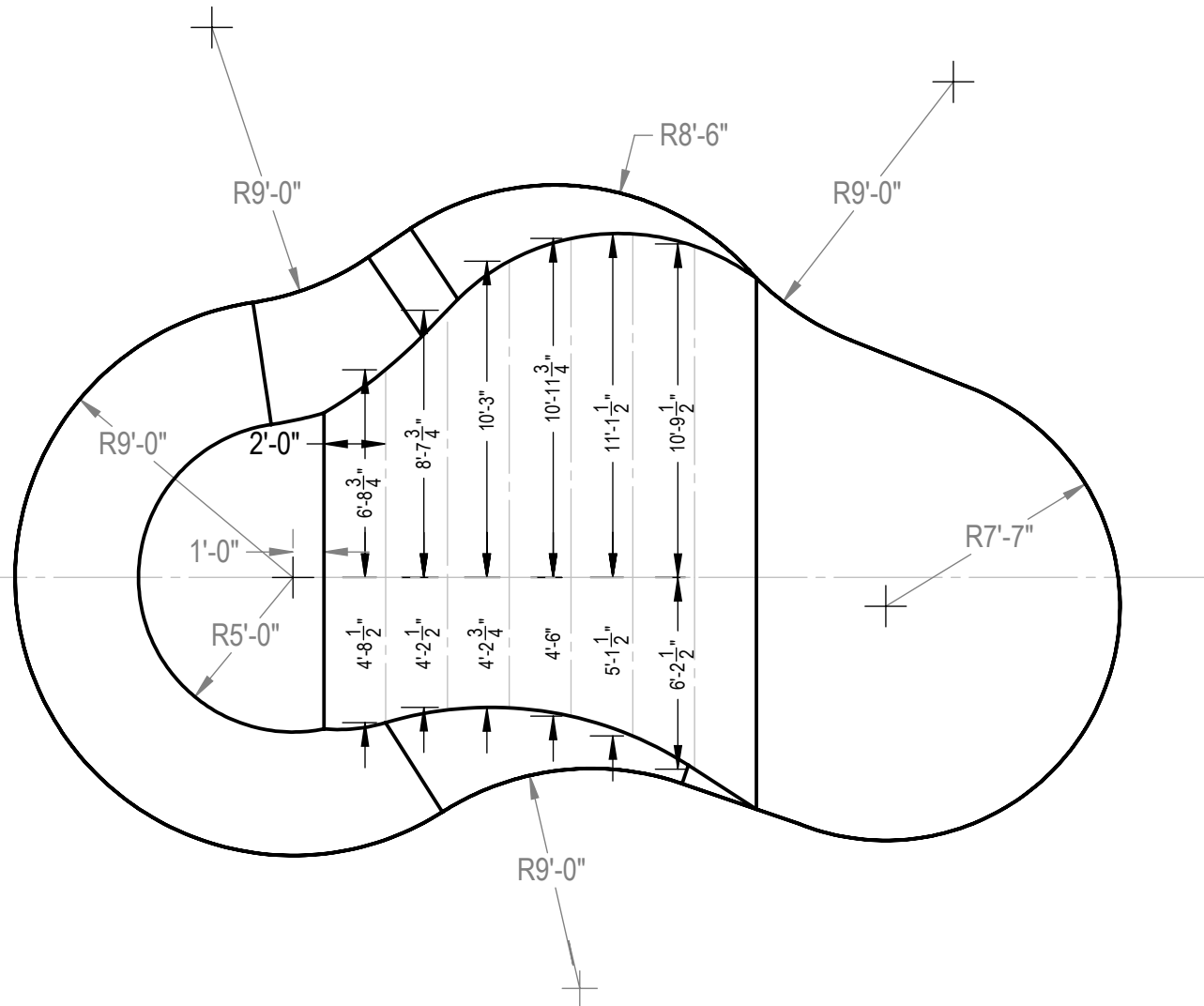

B  
 C

ENGINEERING DRAWING NUMBER: <b>00005037</b>	WEIGHT:	<b>UNLESS OTHERWISE SPECIFIED</b> DIMENSIONS ARE IN INCHES TOLERANCES DECIMALS: X ± 0.1 XX ± 0.01 XXX ± 0.005 XXXX ± 0.0005 ANGULAR: X ± 0.5 THIRD ANGLE PROJECTION 	DESIGNED BY:	CREATION DATE:	<b>HYDRA POOLS</b>  <b>LAYOUT, 21'-8" X 35'-9", LAGOON, LEFT,</b> <b>8' DEEP, 500 SERIES</b>
	lbs		RCOLBOCH	6/10/2013	
	VOLUME:		DETAILED BY:	DETAILED DATE:	
	Inch <sup>3</sup>		JBOSSERDET	10/5/2012	
	COLOR:		LAST REVISED BY:	LAST REVISED DATE:	
	NA		jbosserdet	1/26/2015	
HEAT TREAT:	MATERIAL:	PART NUMBER:	SCALE:	SIZE:	
NA		<b>50929</b>	1:192	<b>A</b>	
FINISH:			SHEET:		
NA			5 OF 6		
TEXTURE:					
NA					

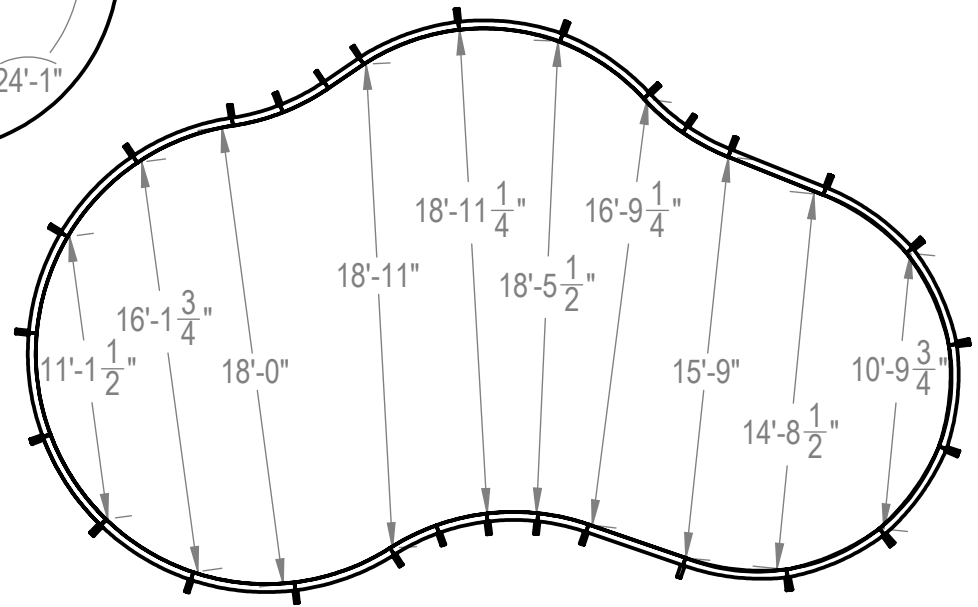
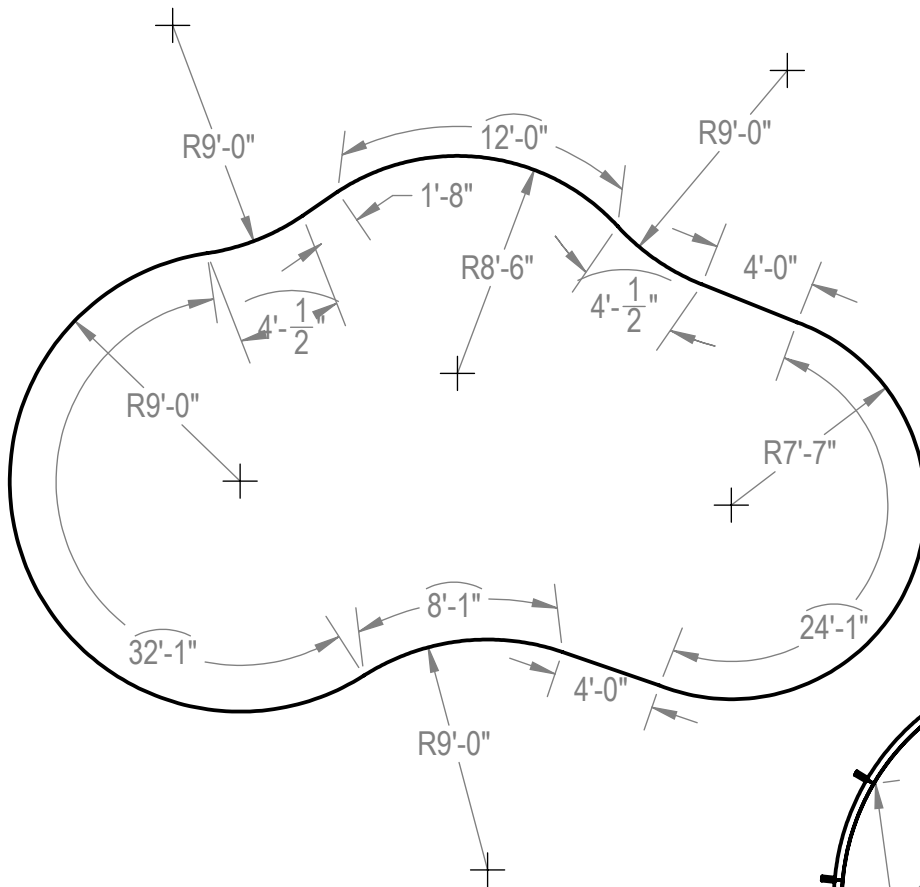

ENGINEERING DRAWING NUMBER:  
00005037

**UNLESS OTHERWISE SPECIFIED**  
DIMENSIONS ARE IN INCHES  
TOLERANCES  
DECIMALS: X ± 0.1  
              XX ± 0.01  
              XXX ± 0.005  
              XXXX ± 0.0005  
ANGULAR: X ± 0.5  
THIRD ANGLE PROJECTION

DESIGNED BY:  
RCOLBOCH  
CREATION DATE:  
6/10/2013  
DETAILED BY:  
JBOSSEDET  
DETAILED DATE:  
10/5/2012  
LAST REVISED BY:  
jbossedet  
LAST REVISED DATE:  
1/26/2015  
MATERIAL:

**HYDRA POOLS**  
TITLE: LAYOUT, 21'-8" X 35'-9", LAGOON, LEFT,  
8' DEEP, 500 SERIES  
PART NUMBER:  
**50929**  
SCALE:  
1:192  
SHEET:  
6 OF 6  
SIZE:  
**A**