

REVISION HISTORY				
REV.	DESCRIPTION	DATE	ECO	BY
B	CORRECTED 50510 HYDRA NUMBER	12/18/2013	NONE	RCOLBOCH
C	UPDATED TAG DATA TO INCLUDE COPING LENGTHS.	1/19/2015	391702	JBOSSERDET

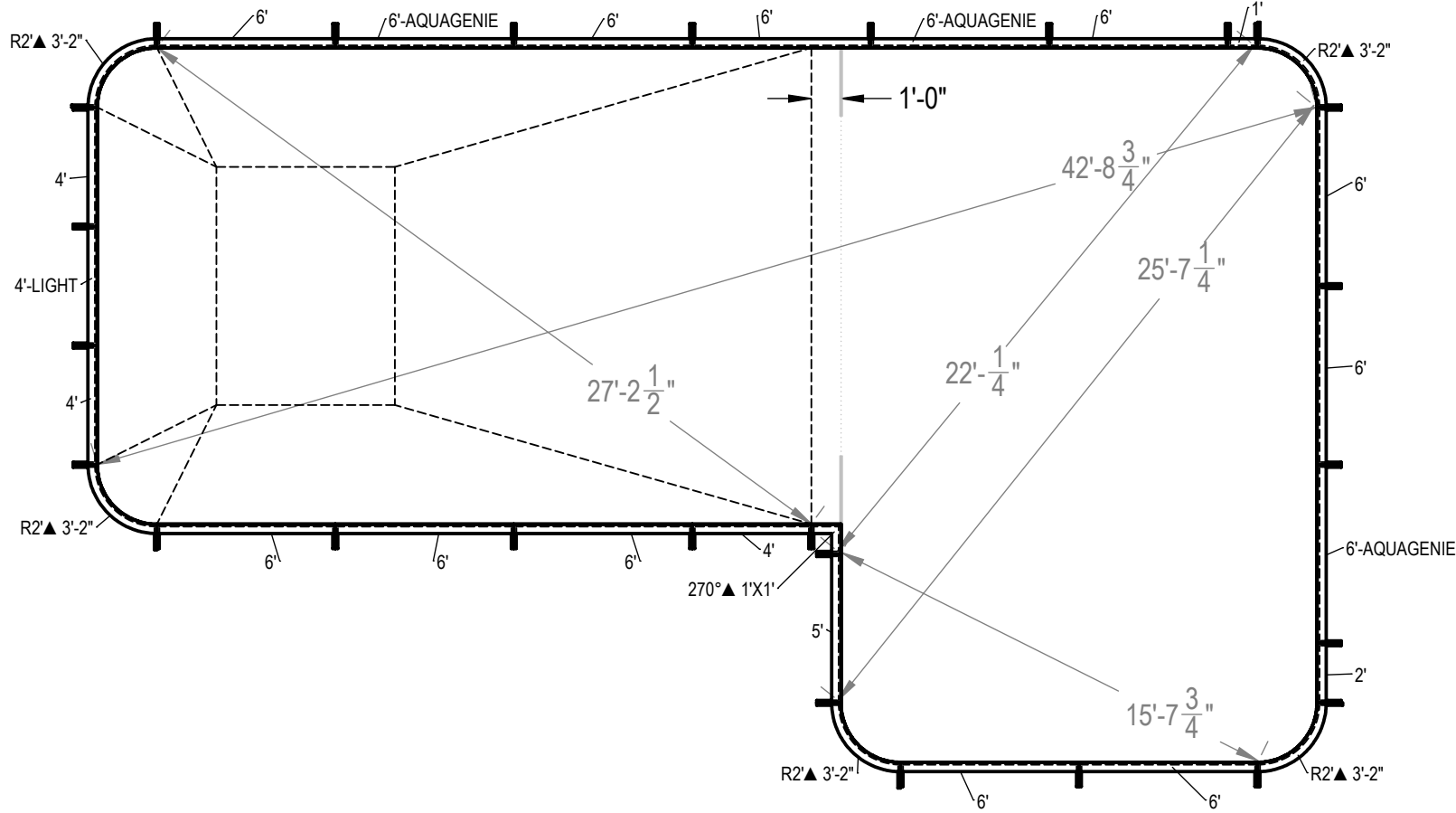

ITEM	FILE NAME	DESCRIPTION	CUSTOMER DRAWING #	VENDOR PART #	QTY.	VENDOR NAME	MATERIAL
1	BRACE	BRACE, 5 TAB, TRANQUILITY - 500 SERIES	HP599	HP599	26	HYDRA POOLS	PS
2	PANEL, 1' LONG	PANEL, 1' LONG - 500 SERIES	HP501	HP501	1	HYDRA POOLS	PS
3	PANEL, 2' LONG	PANEL, 2' LONG - 500 SERIES	HP502	HP502	1	HYDRA POOLS	PS
4	PANEL, 2' RADIUS	PANEL, 2' RADIUS - 500 SERIES	HP552M	HP552M	5	HYDRA POOLS	PS
5	PANEL, 4' LONG	PANEL, 4' LONG - 500 SERIES	HP504	HP504	3	HYDRA POOLS	PS
6	PANEL, 4' LONG WITH LIGHT	PANEL, 4' LONG WITH LIGHT - 500 SERIES	HP504L	HP504L	1	HYDRA POOLS	PS
7	PANEL, 5' LONG	PANEL, 5' LONG - 500 SERIES	HP505	HP505	1	HYDRA POOLS	PS
8	PANEL, 6' LONG	PANEL, 6' LONG - 500 SERIES	HP506	HP506	11	HYDRA POOLS	PS
9	PANEL, 6' LONG WITH AQUA GENIE	PANEL, 6' LONG WITH AQUA GENIE - 500 SERIES	HP506A	HP506A	3	HYDRA POOLS	PS
10	PANEL, L, 270° X 1' X 1'	PANEL, L, 270° X 1' X 1' - 500 SERIES	HP522	HP522	1		PS

- NOTES:**
- THESE ARE FINISHED DIMENSIONS READY FOR THE LINER.
 - DIMENSIONS ARE FROM INSIDE POOL PANELS.
 - THE IDEAL WATER LEVER SHOULD BE TO THE MIDDLE OF THE SKIMMER OPENING(S).
- EXCAVATION NOTES:**
- ROUGH EXCAVATION SHOULD BE 2" DEEPER IN EACH INSTANCE.
 - SOIL TO HAVE MINIMUM BEARING CAPACITY OF 1500 PSF.
 - LOCATE TOP OF POOL AT LEAST 6" ABOVE THE SURROUNDING LAND ELEVATION.
 - SEE "OVER DIG DETAIL" FOR EXCAVATION AROUND POOL.
 - FILL VOIDS UNDER BASE OF PANELS AND TAMP WELL.
 - BACK FILL WITH NON-EXPANSIVE MATERIAL.
 - ANSI / APSP / ICC-5 FOR RESIDENTIAL POOLS, 2003-2007 BOCA CODE SECTION 421.

- IMPORTANT NOTES:**
- THIS DOCUMENT IS FOR ILLUSTRATIVE PURPOSES ONLY. THE DEALER OR CONTRACTOR WHO SELLS OR INSTALLS YOUR POOL IS AN INDEPENDENT CONTRACTOR AND IS NOT AN AGENT OF THE MANUFACTURER. THE CONSTRUCTION METHODS ILLUSTRATED HERE ARE SUGGESTIONS AND APPLY ONLY TO NORMAL GROUND CONDITIONS. THERE MAY BE ADDITIONAL PRECAUTIONS AND/OR METHODS OF CONSTRUCTION. PROPER INSTALLATION IS THE RESPONSIBILITY OF THE DEALER/BUILDER/CONTRACTOR.

ENGINEERING DRAWING NUMBER:
00004872

WEIGHT: lbs	UNLESS OTHERWISE SPECIFIED DIMENSIONS ARE IN INCHES TOLERANCES DECIMALS: X ± .1 XX ± .01 XXX ± .001 XXXX ± .0005 ANGULAR: X ± 0.5 THIRD ANGLE PROJECTION
VOLUME: Inch ³	
COLOR:	
HEAT TREAT:	
FINISH:	
TEXTURE:	

DESIGNED BY: RCOLBOCH	CREATION DATE: 10/5/2011
DETAILED BY: JBOSSERDET	DETAILED DATE: 10/5/2012
LAST REVISED BY: jbosserdet	LAST REVISED DATE: 1/19/2015
MATERIAL:	

HYDRA POOLS

TITLE: LAYOUT, 16' X 41' X 24', TRUE L, LEFT, 2' RADIUS, 8' DEEP, 500 SERIES

PART NUMBER: **50510**

SCALE: 1:192
SHEET: 1 OF 2
SIZE: **A**

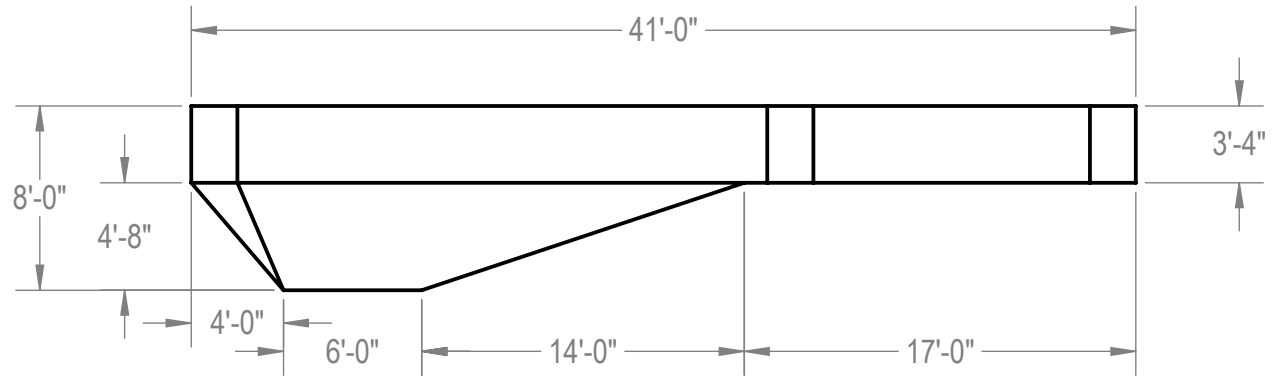
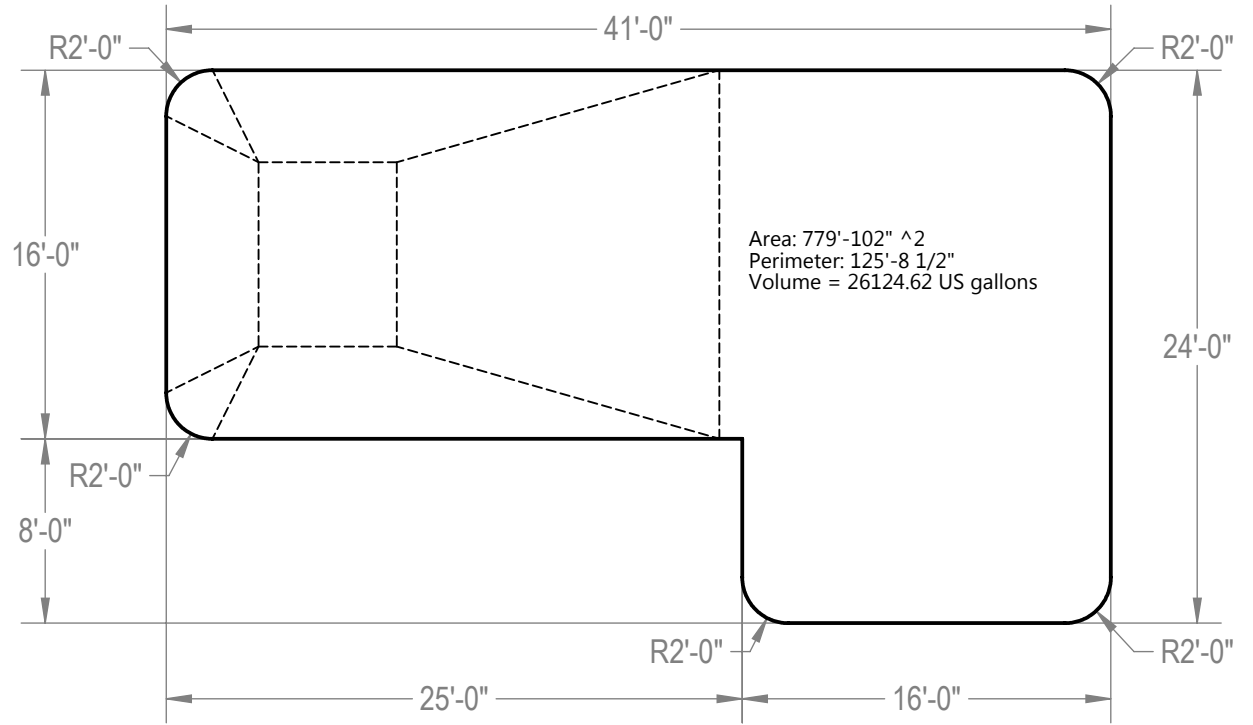
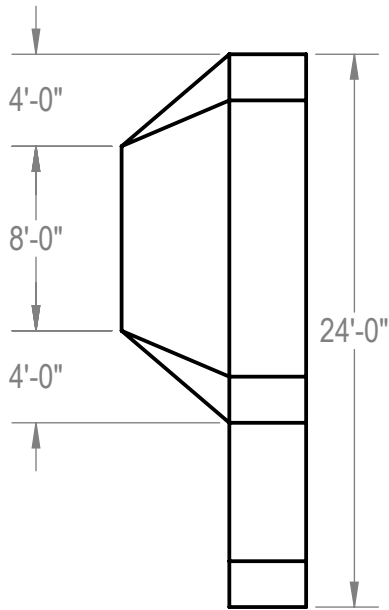

NOTES:

1. THESE ARE FINISHED DIMENSIONS READY FOR THE LINER.
2. DIMENSIONS ARE FROM INSIDE POOL PANELS.
3. THE IDEAL WATER LEVEL SHOULD BE TO THE MIDDLE OF THE SKIMMER OPENING(S).

EXCAVATION NOTES:

4. ROUGH EXCAVATION SHOULD BE 2" DEEPER IN EACH INSTANCE.
5. SOIL TO HAVE MINIMUM BEARING CAPACITY OF 1500 PSF.
6. LOCATE TOP OF POOL AT LEAST 6" ABOVE THE SURROUNDING LAND ELEVATION.
7. SEE "OVER DIG DETAIL" FOR EXCAVATION AROUND POOL.
8. FILL VOIDS UNDER BASE OF PANELS AND TAMP WELL.
9. BACK FILL WITH NON-EXPANSIVE MATERIAL.
10. ANSI / APSP / ICC-5 FOR RESIDENTIAL POOLS, 2003-2007 BOCA CODE SECTION 421.

IMPORTANT NOTES:

11. THIS DOCUMENT IS FOR ILLUSTRATIVE PURPOSES ONLY. THE DEALER OR CONTRACTOR WHO SELLS OR INSTALLS YOUR POOL IS AN INDEPENDENT CONTRACTOR AND IS NOT AN AGENT OF THE MANUFACTURER. THE CONSTRUCTION METHODS ILLUSTRATED HERE ARE SUGGESTIONS AND APPLY ONLY TO NORMAL GROUND CONDITIONS. THERE MAY BE ADDITIONAL PRECAUTIONS AND/OR METHODS OF CONSTRUCTION. PROPER INSTALLATION IS THE RESPONSIBILITY OF THE DEALER/BUILDER/CONTRACTOR.

ENGINEERING DRAWING NUMBER: 00004872	WEIGHT:	UNLESS OTHERWISE SPECIFIED DIMENSIONS ARE IN INCHES TOLERANCES DECIMALS: X ± .1 XX ± .01 XXX ± .001 XXXX ± .0005 ANGULAR: X ± 0.5 THIRD ANGLE PROJECTION	DESIGNED BY:	CREATION DATE:	HYDRA POOLS
	lbs		RCOLBOCH	2/19/2013	
	VOLUME:		Detailed BY:	DETAILED DATE:	
	Inch ³		JBOSSERDET	10/5/2012	
COLOR:	LAST REVISED BY:	LAST REVISED DATE:	TITLE:	LAYOUT, 16' X 41' X 24', TRUE L, LEFT, 2' RADIUS, 8' DEEP, 500 SERIES	
NA	jbosserdet	1/19/2015	PART NUMBER:		
HEAT TREAT:	MATERIAL:		50510		
NA			SCALE: 1:128 SHEET: 2 OF 2		
FINISH:			SIZE:	A	
NA					
TEXTURE:					
NA					