

REVISION HISTORY				
REV.	DESCRIPTION	DATE	ECO	BY
B	RELEASED FOR PRODUCTION	12/9/2013	NONE	RCOLBOCH
C	UPDATED TAG DATA TO INCLUDE COPING LENGTHS.	1/12/2015	391702	JBOSSEDET

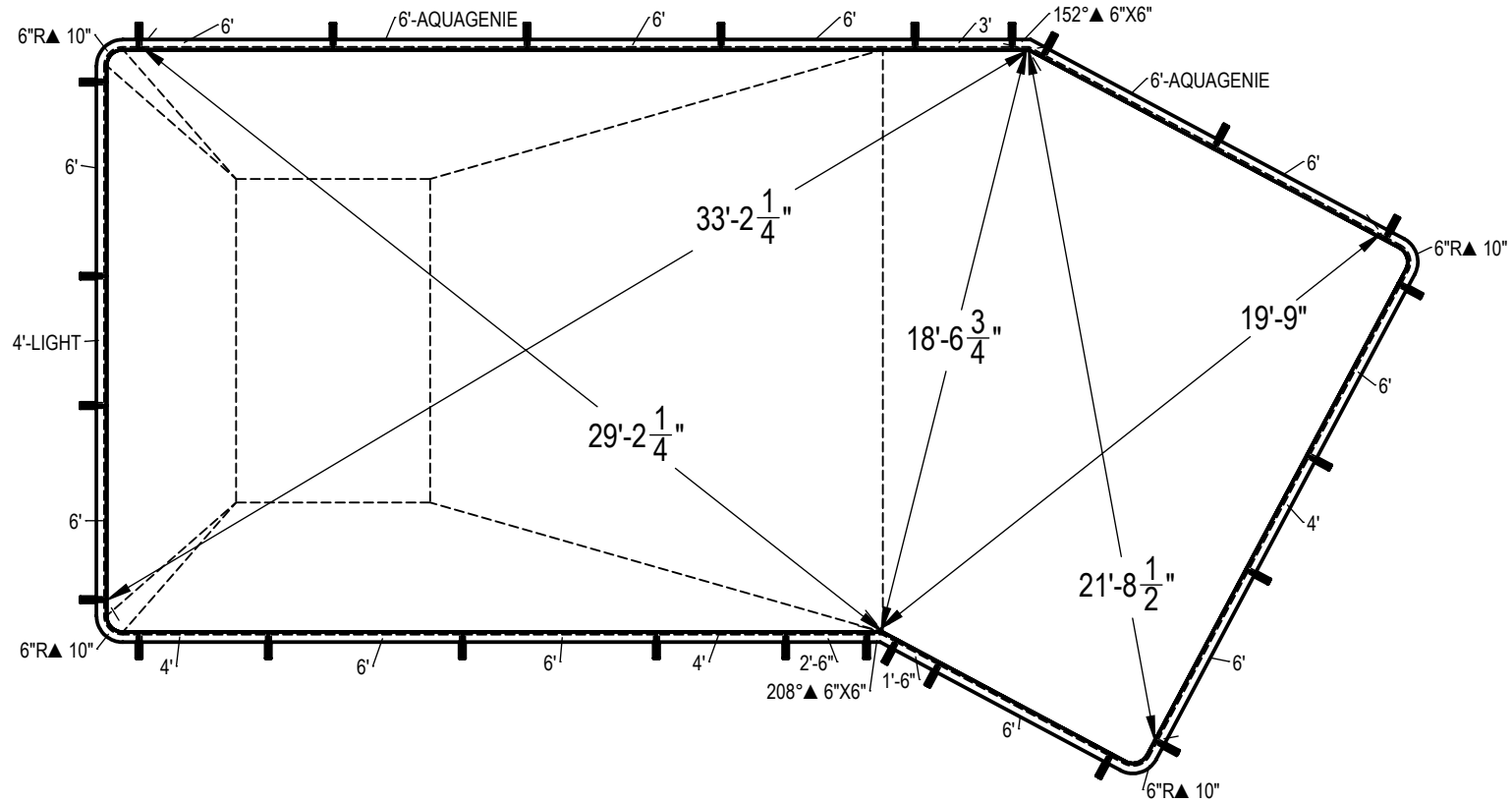

ITEM	FILE NAME	DESCRIPTION	CUSTOMER DRAWING #	VENDOR PART #	QTY.	VENDOR NAME	MATERIAL
1	BRACE	BRACE, 5 TAB, TRANQUILITY - 500 SERIES	HP599	HP599	26	HYDRA POOLS	PS
2	PANEL, 1'-6 IN LONG	PANEL 1'-6" LONG - 500 SERIES	HP582S	HP582S	1	HYDRA POOLS	PS
3	PANEL, 2'-6 IN LONG	PANEL, 2'-6" LONG - 500 SERIES	HP583S	HP583S	1	HYDRA POOLS	PS
4	PANEL, 3' LONG	PANEL, 3' LONG - 500 SERIES	HP503	HP503	1	HYDRA POOLS	PS
5	PANEL, 4' LONG	PANEL, 4' LONG - 500 SERIES	HP504	HP504	3	HYDRA POOLS	PS
6	PANEL, 4' LONG WITH LIGHT	PANEL, 4' LONG WITH LIGHT - 500 SERIES	HP504L	HP504L	1	HYDRA POOLS	PS
7	PANEL, 6 IN RADIUS, 6 IN X 6 IN	PANEL, 6" RADIUS - 500 SERIES	HP556	HP556	4	HYDRA POOLS	PS
8	PANEL, 6' LONG	PANEL, 6' LONG - 500 SERIES	HP506	HP506	11	HYDRA POOLS	PS
9	PANEL, 6' LONG WITH AQUA GENIE	PANEL, 6' LONG WITH AQUA GENIE - 500 SERIES	HP506A	HP506A	2	HYDRA POOLS	PS
10	PANEL, L, 152° X 6 IN X 6 IN	PANEL, L, 152° X 6" X 6" - 500 SERIES	HP521	HP521	1	HYDRA POOLS	PS
11	PANEL, L, 208° X 6 IN X 6 IN	PANEL, L, 208° X 6" X 6" - 500 SERIES	HP520	HP520	1	HYDRA POOLS	PS

**NOTES:**

- THESE ARE FINISHED DIMENSIONS READY FOR THE LINER.
- DIMENSIONS ARE FROM INSIDE POOL PANELS.
- THE IDEAL WATER LEVER SHOULD BE TO THE MIDDLE OF THE SKIMMER OPENING(S).

**EXCAVATION NOTES:**

- ROUGH EXCAVATION SHOULD BE 2" DEEPER IN EACH INSTANCE.
- SOIL TO HAVE MINIMUM BEARING CAPACITY OF 2000 PSF.
- LOCATE TOP OF POOL AT LEAST 6" ABOVE THE SURROUNDING LAND ELEVATION.
- SEE "OVER DIG DETAIL" FOR EXCAVATION AROUND POOL.
- FILL VOIDS UNDER BASE OF PANELS AND TAMP WELL.
- BACK FILL WITH NON-EXPANSIVE MATERIAL.

**IMPORTANT NOTES:**

THIS DOCUMENT IS FOR ILLUSTRATIVE PURPOSES ONLY. THE DEALER OR CONTRACTOR WHO SELLS OR INSTALLS YOUR POOL IS AN INDEPENDENT CONTRACTOR AND IS NOT AN AGENT OF THE MANUFACTURER. THE CONSTRUCTION METHODS ILLUSTRATED HERE ARE SUGGESTIONS AND APPLY ONLY TO NORMAL GROUND CONDITIONS. THERE MAY BE ADDITIONAL PRECAUTIONS AND/OR METHODS OF CONSTRUCTION. PROPER INSTALLATION IS THE RESPONSIBILITY OF THE DEALER/BUILDER/CONTRACTOR.

ENGINEERING DRAWING NUMBER: <b>00004749</b>	WEIGHT:	<b>UNLESS OTHERWISE SPECIFIED</b> DIMENSIONS ARE IN INCHES TOLERANCES DECIMALS: X ± 0.1 XX ± 0.01 XXX ± 0.005 XXXX ± 0.0005  ANGULAR: X ± 0.5 THIRD ANGLE PROJECTION	DESIGNED BY:	CREATION DATE:	<b>HYDRA POOLS</b>
	VOLUME: Inch <sup>3</sup>		RCOLBOCH	8/12/2013	
	COLOR:		DETAILED BY:	DETAILED DATE:	
	HEAT TREAT:		JBOSSEDET	10/5/2012	
FINISH:	LAST REVISED BY:	LAST REVISED DATE:	TITLE: <b>LAYOUT, 18' X 40'-2", LAZY L, LEFT, 6" RADIUS, 8' DEEP, 500 SERIES</b>		
TEXTURE:	jbosserdet	1/12/2015			
PART NUMBER: <b>50420</b>			SCALE: 1:192	SIZE: A	

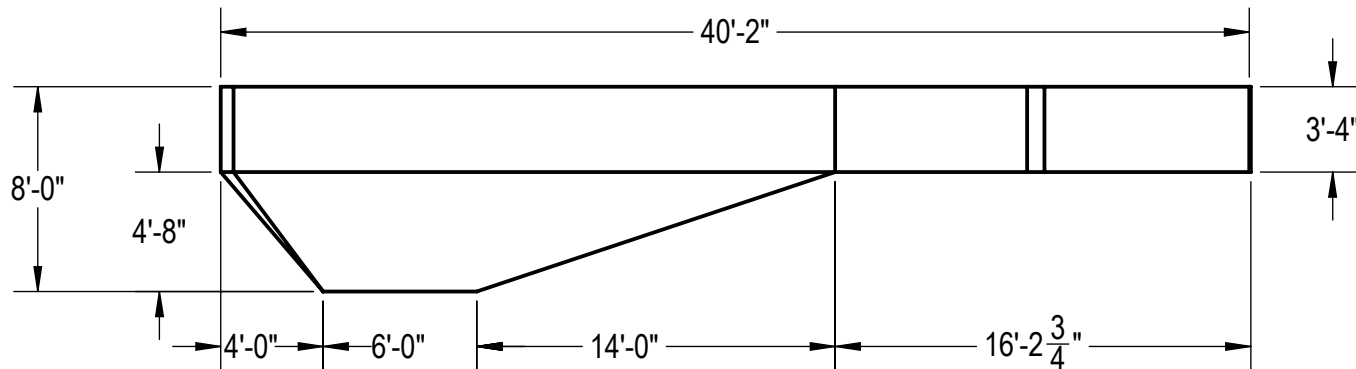
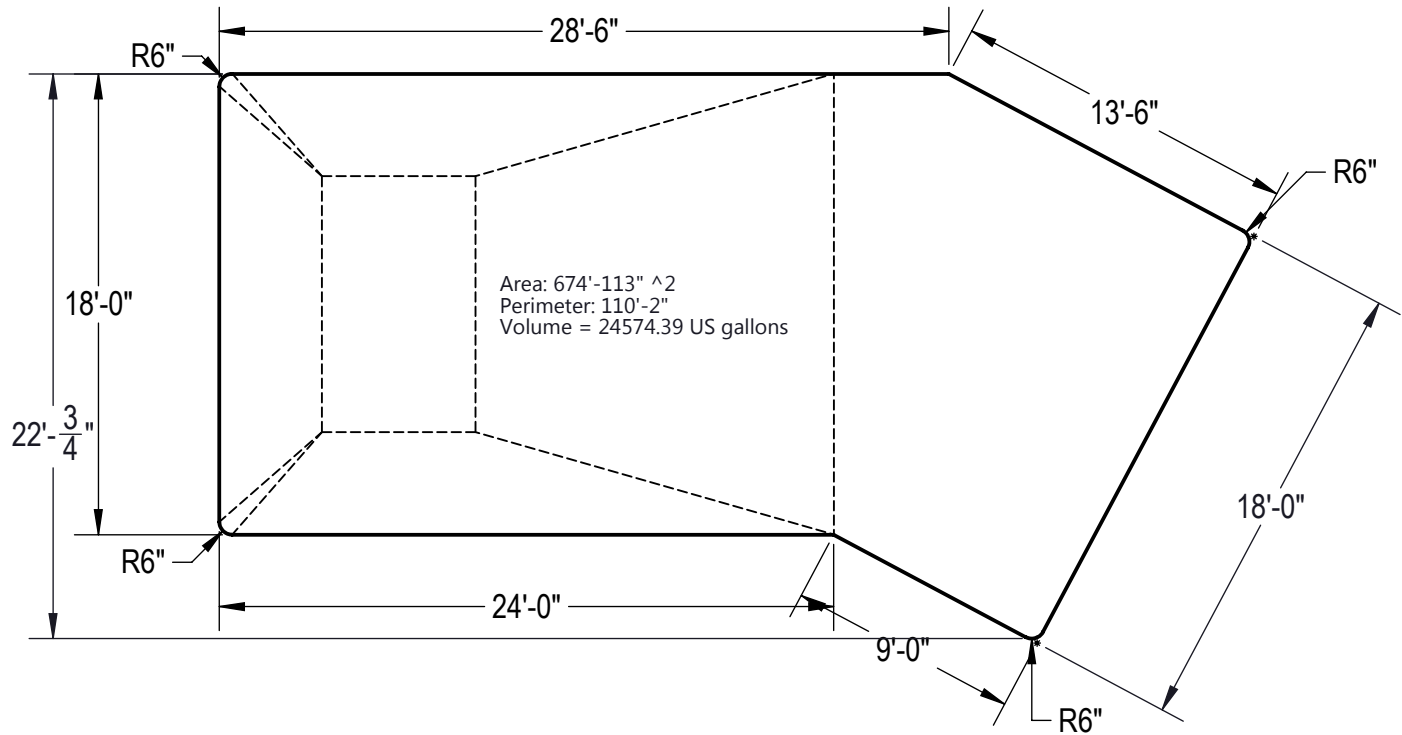
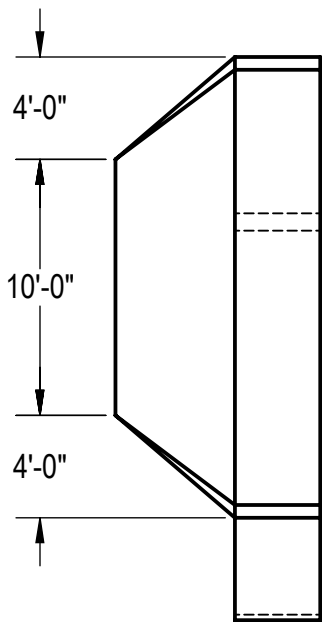

**NOTES:**

1. THESE ARE FINISHED DIMENSIONS READY FOR THE LINER.
2. DIMENSIONS ARE FROM INSIDE POOL PANELS.
3. THE IDEAL WATER LEVEL SHOULD BE TO THE MIDDLE OF THE SKIMMER OPENING(S).

**EXCAVATION NOTES:**

4. ROUGH EXCAVATION SHOULD BE 2" DEEPER IN EACH INSTANCE.
5. SOIL TO HAVE MINIMUM BEARING CAPACITY OF 2000 PSF.
6. LOCATE TOP OF POOL AT LEAST 6" ABOVE THE SURROUNDING LAND ELEVATION.
7. SEE "OVER DIG DETAIL" FOR EXCAVATION AROUND POOL.
8. FILL VOIDS UNDER BASE OF PANELS AND TAMP WELL.
9. BACK FILL WITH NON-EXPANSIVE MATERIAL.

**IMPORTANT NOTES:**

THIS DOCUMENT IS FOR ILLUSTRATIVE PURPOSES ONLY. THE DEALER OR CONTRACTOR WHO SELLS OR INSTALLS YOUR POOL IS AN INDEPENDENT CONTRACTOR AND IS NOT AN AGENT OF THE MANUFACTURER. THE CONSTRUCTION METHODS ILLUSTRATED HERE ARE SUGGESTIONS AND APPLY ONLY TO NORMAL GROUND CONDITIONS. THERE MAY BE ADDITIONAL PRECAUTIONS AND/OR METHODS OF CONSTRUCTION. PROPER INSTALLATION IS THE RESPONSIBILITY OF THE DEALER/BUILDER/CONTRACTOR.

ENGINEERING DRAWING NUMBER: <b>00004749</b>	WEIGHT:	<b>UNLESS OTHERWISE SPECIFIED</b> DIMENSIONS ARE IN INCHES TOLERANCES DECIMALS: X ± .1 XX ± .01 XXX ± .001 XXXX ± .0005  ANGULAR: X ± 0.5 THIRD ANGLE PROJECTION 	DESIGNED BY:	CREATION DATE:	<b>HYDRA POOLS</b>	
	lbs		RCOLBOCH	8/12/2013		
	VOLUME:		Detailed by:	Detailed Date:	TITLE: <b>LAYOUT, 18' X 40'-2", LAZY L, LEFT, 6" RADIUS, 8' DEEP, 500 SERIES</b>	
	Inch <sup>3</sup>		JBOSSERDET	10/5/2012		
	COLOR:		LAST REVISED BY:	LAST REVISED DATE:		
NA	Jbossdet	1/12/2015	PART NUMBER:	SCALE:	SIZE:	
HEAT TREAT:	MATERIAL:		<b>50420</b>	1:128	<b>A</b>	
NA				SHEET:		
FINISH:				2 OF 2		
NA						
TEXTURE:						
NA						