

REVISION HISTORY				
REV.	DESCRIPTION	DATE	ECO	BY
A	RELEASED FOR PRODUCTION	10/17/2013	NONE	RCOLBOCH
B	UPDATED TAG DATA TO INCLUDE COPING LENGTHS.	12/23/2014	391702	JBOSSERDET

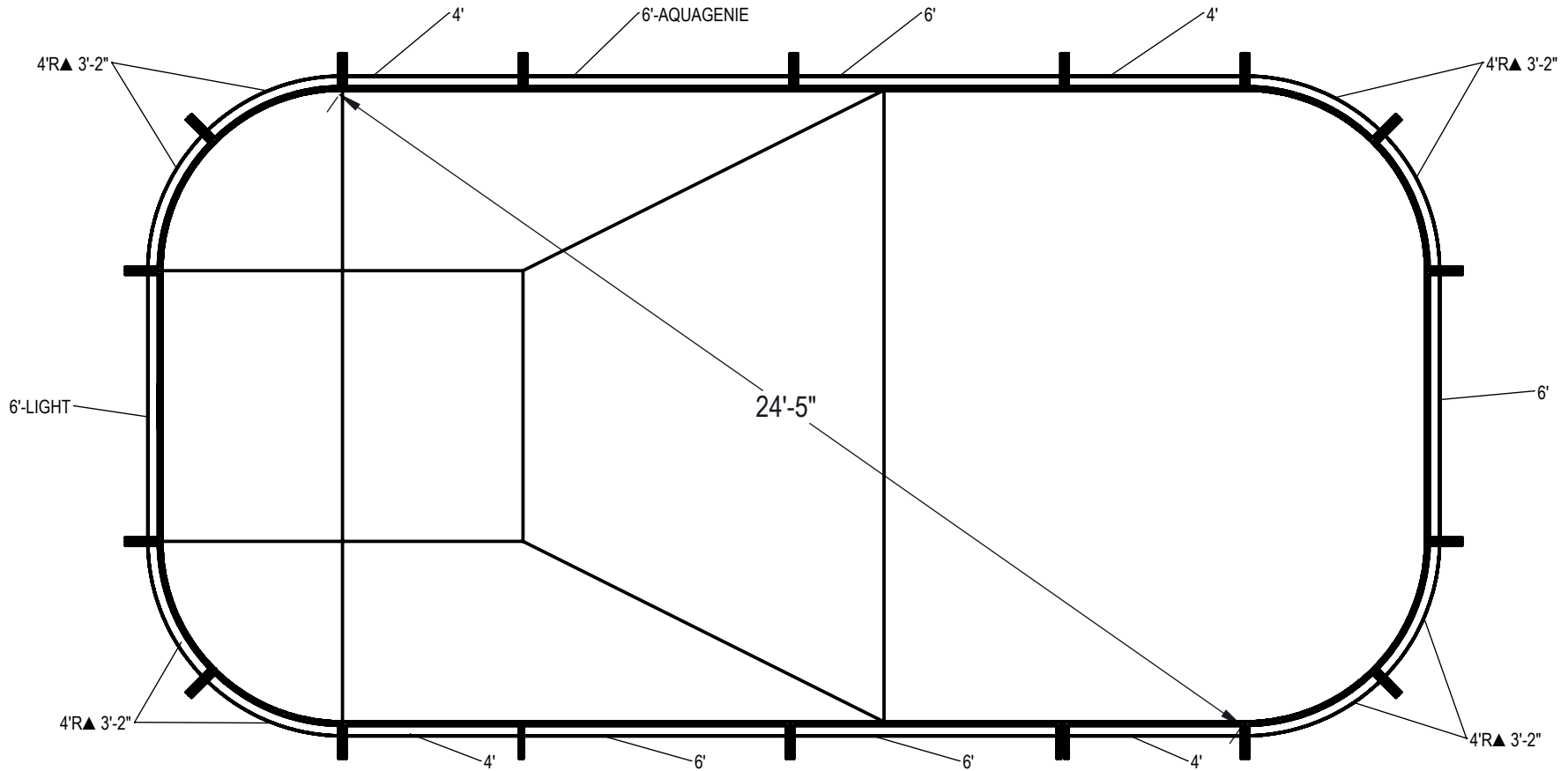

NOTES:

- THESE ARE FINISHED DIMENSIONS READY FOR THE LINER.
 - DIMENSIONS ARE FROM INSIDE POOL PANELS.
 - THE IDEAL WATER LEVEL SHOULD BE TO THE MIDDLE OF THE SKIMMER OPENING(S).
- EXCAVATION NOTES:**
- ROUGH EXCAVATION SHOULD BE 2" DEEPER IN EACH INSTANCE.
 - SOIL TO HAVE MINIMUM BEARING CAPACITY OF 1500 PSF.
 - LOCATE TOP OF POOL AT LEAST 6" ABOVE THE SURROUNDING LAND ELEVATION.
 - SEE "OVER DIG DETAIL" FOR EXCAVATION AROUND POOL.
 - FILL VOIDS UNDER BASE OF PANELS AND TAMP WELL.
 - BACK FILL WITH NON-EXPANSIVE MATERIAL.
 - ANSI / APSP / ICC-5 FOR RESIDENTIAL POOLS, 2003-2007 BOCA CODE SECTION 421.

IMPORTANT NOTES:

- THIS DOCUMENT IS FOR ILLUSTRATIVE PURPOSES ONLY. THE DEALER OR CONTRACTOR WHO SELLS OR INSTALLS YOUR POOL IS AN INDEPENDENT CONTRACTOR AND IS NOT AN AGENT OF THE MANUFACTURER. THE CONSTRUCTION METHODS ILLUSTRATED HERE ARE SUGGESTIONS AND APPLY ONLY TO NORMAL GROUND CONDITIONS. THERE MAY BE ADDITIONAL PRECAUTIONS AND/OR METHODS OF CONSTRUCTION. PROPER INSTALLATION IS THE RESPONSIBILITY OF THE DEALER/BUILDER/CONTRACTOR.

ITEM	FILE NAME	DESCRIPTION	CUSTOMER DRAWING #	VENDOR PART #	QTY.	VENDOR NAME	MATERIAL
1	BRACE	BRACE, 5 TAB, TRANQUILITY - 500 SERIES	HP599	HP599	18	HYDRA POOLS	PS
2	PANEL, 4' LONG	PANEL, 4' LONG - 500 SERIES	HP504	HP504	4	HYDRA POOLS	PS
3	PANEL, 4' RADIUS	PANEL, 4' RADIUS - 500 SERIES	HP554	HP554	8	HYDRA POOLS	PS
4	PANEL, 6' LONG	PANEL, 6' LONG - 500 SERIES	HP506	HP506	4	HYDRA POOLS	PS
5	PANEL, 6' LONG WITH AQUA GENIE	PANEL, 6' LONG WITH AQUA GENIE - 500 SERIES	HP506A	HP506A	1	HYDRA POOLS	PS
6	PANEL, 6' LONG WITH LIGHT	PANEL, 6' LONG WITH LIGHT - 500 SERIES	HP506L	HP506L	1	HYDRA POOLS	PS

ENGINEERING DRAWING NUMBER: 00004177	WEIGHT:	UNLESS OTHERWISE SPECIFIED DIMENSIONS ARE IN INCHES TOLERANCES DECIMALS: X ± .1 XX ± .01 XXX ± .001 XXXX ± .0005 ANGULAR: X ± 0.5 THIRD ANGLE PROJECTION	DESIGNED BY:	CREATION DATE:	HYDRA POOLS LAYOUT, RECTANGLE, 14' X 28', 6' DEEP, 4' RADIUS, 400 SERIES	
	VOLUME:		rcolboch	10/17/2013		
	Inch ³		DETAILED BY:	10/5/2012		
	COLOR:		JBOSSERDET	LAST REVISED BY:		12/23/2014
	HEAT TREAT:		jbosserdet	MATERIAL:		
	FINISH:					
TEXTURE:						
PART NUMBER: 50114					SCALE: 1:96	SIZE: A
					SHEET: 1 OF 2	

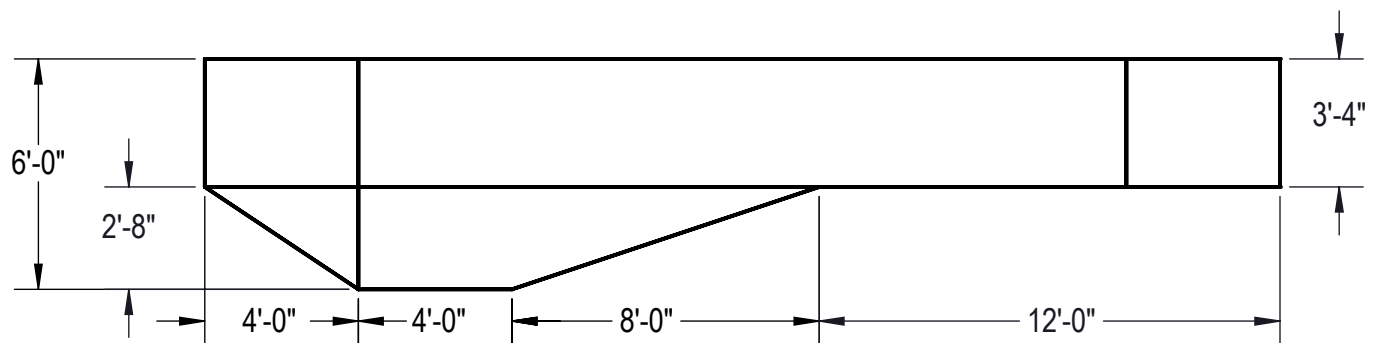
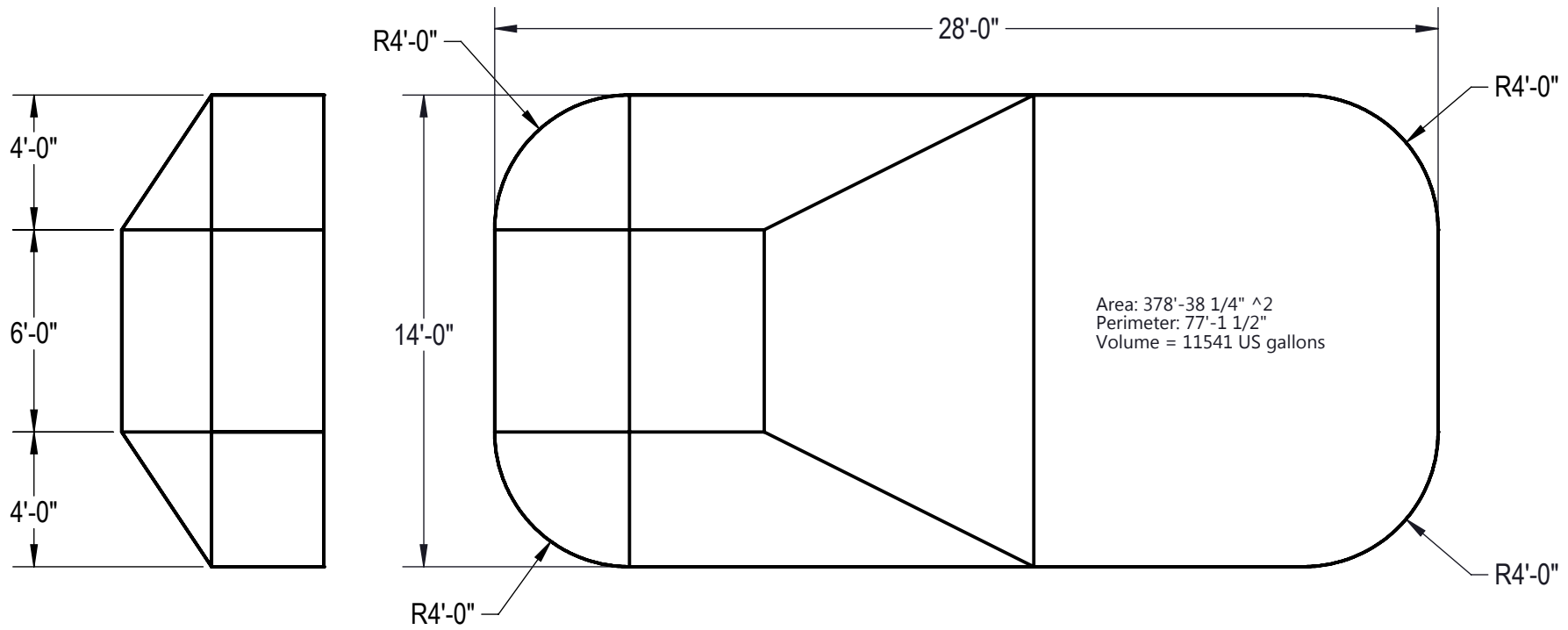

- NOTES:**
- THESE ARE FINISHED DIMENSIONS READY FOR THE LINER.
 - DIMENSIONS ARE FROM INSIDE POOL PANELS.
 - THE IDEAL WATER LEVER SHOULD BE TO THE MIDDLE OF THE SKIMMER OPENING(S).
- EXCAVATION NOTES:**
- ROUGH EXCAVATION SHOULD BE 2" DEEPER IN EACH INSTANCE.
 - SOIL TO HAVE MINIMUM BEARING CAPACITY OF 1500 PSF.
 - LOCATE TOP OF POOL AT LEAST 6" ABOVE THE SURROUNDING LAND ELEVATION.
 - SEE "OVER DIG DETAIL" FOR EXCAVATION AROUND POOL.
 - FILL VOIDS UNDER BASE OF PANELS AND TAMP WELL.
 - BACK FILL WITH NON-EXPANSIVE MATERIAL.
 - ANSI / APSP / ICC-5 FOR RESIDENTIAL POOLS, 2003-2007 BOCA CODE SECTION 421.
- IMPORTANT NOTES:**
- THIS DOCUMENT IS FOR ILLUSTRATIVE PURPOSES ONLY. THE DEALER OR CONTRACTOR WHO SELLS OR INSTALLS YOUR POOL IS AN INDEPENDENT CONTRACTOR AND IS NOT AN AGENT OF THE MANUFACTURER. THE CONSTRUCTION METHODS ILLUSTRATED HERE ARE SUGGESTIONS AND APPLY ONLY TO NORMAL GROUND CONDITIONS. THERE MAY BE ADDITIONAL PRECAUTIONS AND/OR METHODS OF CONSTRUCTION. PROPER INSTALLATION IS THE RESPONSIBILITY OF THE DEALER/BUILDER/CONTRACTOR.

ENGINEERING DRAWING NUMBER: 0004177	WEIGHT:	UNLESS OTHERWISE SPECIFIED DIMENSIONS ARE IN INCHES TOLERANCES DECIMALS: X ± .1 XX ± .01 XXX ± .001 XXXX ± .0005 ANGULAR: X ± 0.5 THIRD ANGLE PROJECTION	DESIGNED BY:	CREATION DATE:	HYDRA POOLS LAYOUT, RECTANGLE, 14' X 28', 6' DEEP, 4' RADIUS, 400 SERIES
	VOLUME:		RCOLBOCH	6/4/2013	
	Inch ³		DETAILED BY:	10/5/2012	
	COLOR:		JBOSSERDET	LAST REVISED DATE:	
NA	HEAT TREAT:	LAST REVISED BY:	jbosserdet	TITLE:	PART NUMBER: 50114
NA	FINISH:	MATERIAL:		SCALE: 1:96	
NA	TEXTURE:				SHEET: 2 OF 2