

REVISION HISTORY				
REV.	DESCRIPTION	DATE	ECO	BY
A	RELEASED FOR PRODUCTION	10/16/2013	NONE	RCOLBOCH
B	UPDATED TAG DATA TO INCLUDE COPING LENGTHS.	12/23/2014	391702	JBOSSERDET

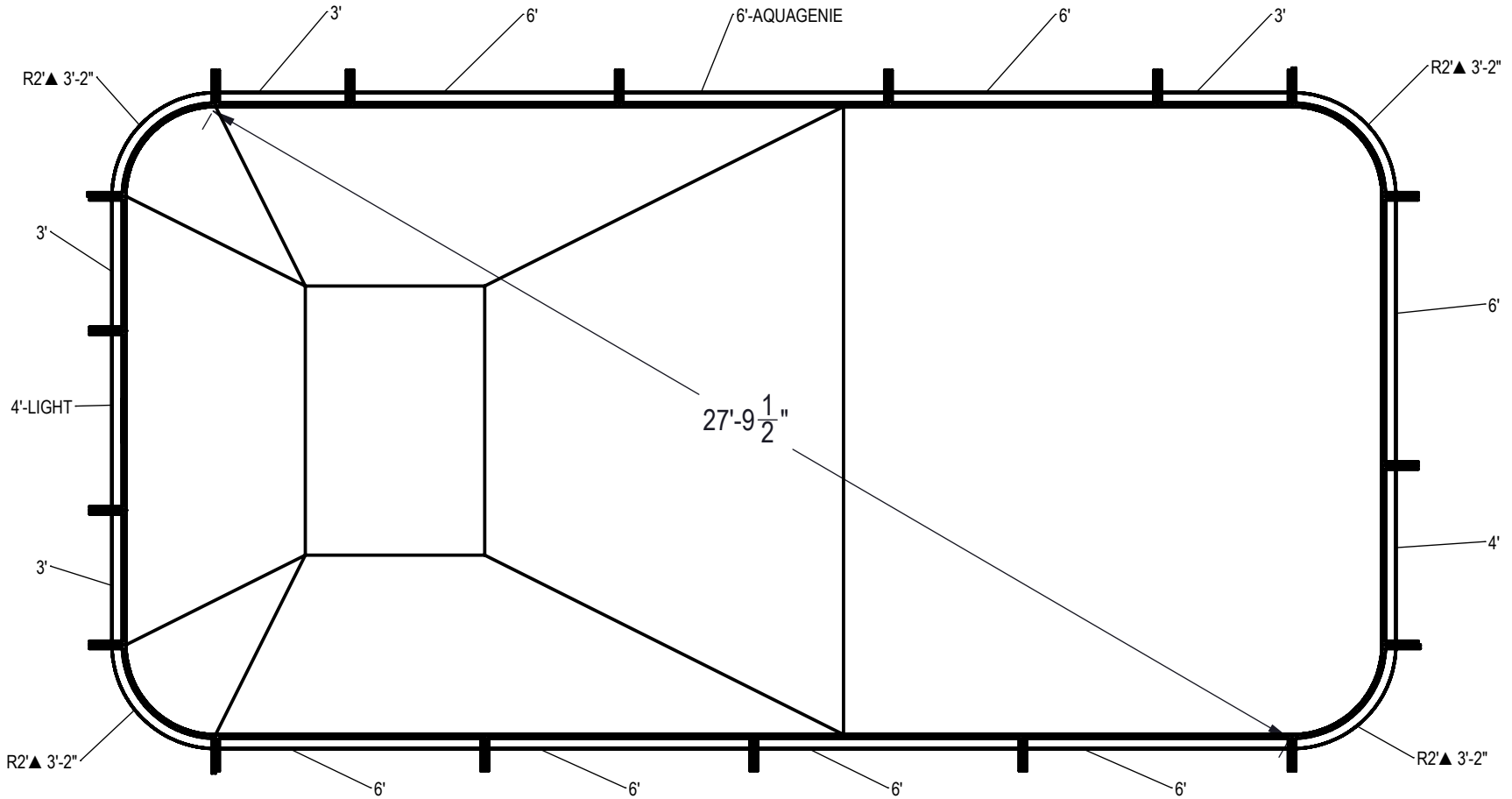

- NOTES:**
- THESE ARE FINISHED DIMENSIONS READY FOR THE LINER.
 - DIMENSIONS ARE FROM INSIDE POOL PANELS.
 - THE IDEAL WATER LEVER SHOULD BE TO THE MIDDLE OF THE SKIMMER OPENING(S).

- EXCAVATION NOTES:**
- ROUGH EXCAVATION SHOULD BE 2" DEEPER IN EACH INSTANCE.
 - SOIL TO HAVE MINIMUM BEARING CAPACITY OF 1500 PSF.
 - LOCATE TOP OF POOL AT LEAST 6" ABOVE THE SURROUNDING LAND ELEVATION.
 - SEE "OVER DIG DETAIL" FOR EXCAVATION AROUND POOL.
 - FILL VOIDS UNDER BASE OF PANELS AND TAMP WELL.
 - BACK FILL WITH NON-EXPANSIVE MATERIAL.
 - ANSI / APSP / ICC-5 FOR RESIDENTIAL POOLS, 2003-2007 BOCA CODE SECTION 421.

- IMPORTANT NOTES:**
- THIS DOCUMENT IS FOR ILLUSTRATIVE PURPOSES ONLY. THE DEALER OR CONTRACTOR WHO SELLS OR INSTALLS YOUR POOL IS AN INDEPENDENT CONTRACTOR AND IS NOT AN AGENT OF THE MANUFACTURER. THE CONSTRUCTION METHODS ILLUSTRATED HERE ARE SUGGESTIONS AND APPLY ONLY TO NORMAL GROUND CONDITIONS. THERE MAY BE ADDITIONAL PRECAUTIONS AND/OR METHODS OF CONSTRUCTION. PROPER INSTALLATION IS THE RESPONSIBILITY OF THE DEALER/BUILDER/CONTRACTOR.

ITEM	FILE NAME	DESCRIPTION	CUSTOMER DRAWING #	VENDOR PART #	QTY.	VENDOR NAME	MATERIAL
1	BRACE	BRACE, 5 TAB, TRANQUILITY - 500 SERIES	HP599	HP599	18	HYDRA POOLS	PS
2	PANEL, 2' RADIUS	PANEL, 2' RADIUS - 500 SERIES	HP552M	HP552M	4	HYDRA POOLS	PS
3	PANEL, 3' LONG	PANEL, 3' LONG - 500 SERIES	HP503	HP503	4	HYDRA POOLS	PS
4	PANEL, 4' LONG	PANEL, 4' LONG - 500 SERIES	HP504	HP504	1	HYDRA POOLS	PS
5	PANEL, 4' LONG WITH LIGHT	PANEL, 4' LONG WITH LIGHT - 500 SERIES	HP504L	HP504L	1	HYDRA POOLS	PS
6	PANEL, 6' LONG	PANEL, 6' LONG - 500 SERIES	HP506	HP506	7	HYDRA POOLS	PS
7	PANEL, 6' LONG WITH AQUA GENIE	PANEL, 6' LONG WITH AQUA GENIE - 500 SERIES	HP506A	HP506A	1	HYDRA POOLS	PS

ENGINEERING DRAWING NUMBER: 00004169	WEIGHT: lbs	UNLESS OTHERWISE SPECIFIED DIMENSIONS ARE IN INCHES TOLERANCES DECIMALS: X ± .1 XX ± .01 XXX ± .001 XXXX ± .0005 ANGULAR: X ± 0.5 THIRD ANGLE PROJECTION	DESIGNED BY: RCOLBOCH	CREATION DATE: 4/29/2013	HYDRA POOLS LAYOUT, RECTANGLE, 14' X 28', 6' DEEP, 2' RADIUS, 500 SERIES
	VOLUME: Inch ³		DETAILED BY: JBOSSERDET	DETAILED DATE: 10/5/2012	
	COLOR: NA		LAST REVISED BY: jbosserdet	LAST REVISED DATE: 12/23/2014	
	HEAT TREAT: NA		MATERIAL:		
FINISH: NA					PART NUMBER: 50112
TEXTURE: NA					SCALE: 1:96 SHEET: 1 OF 2
					A

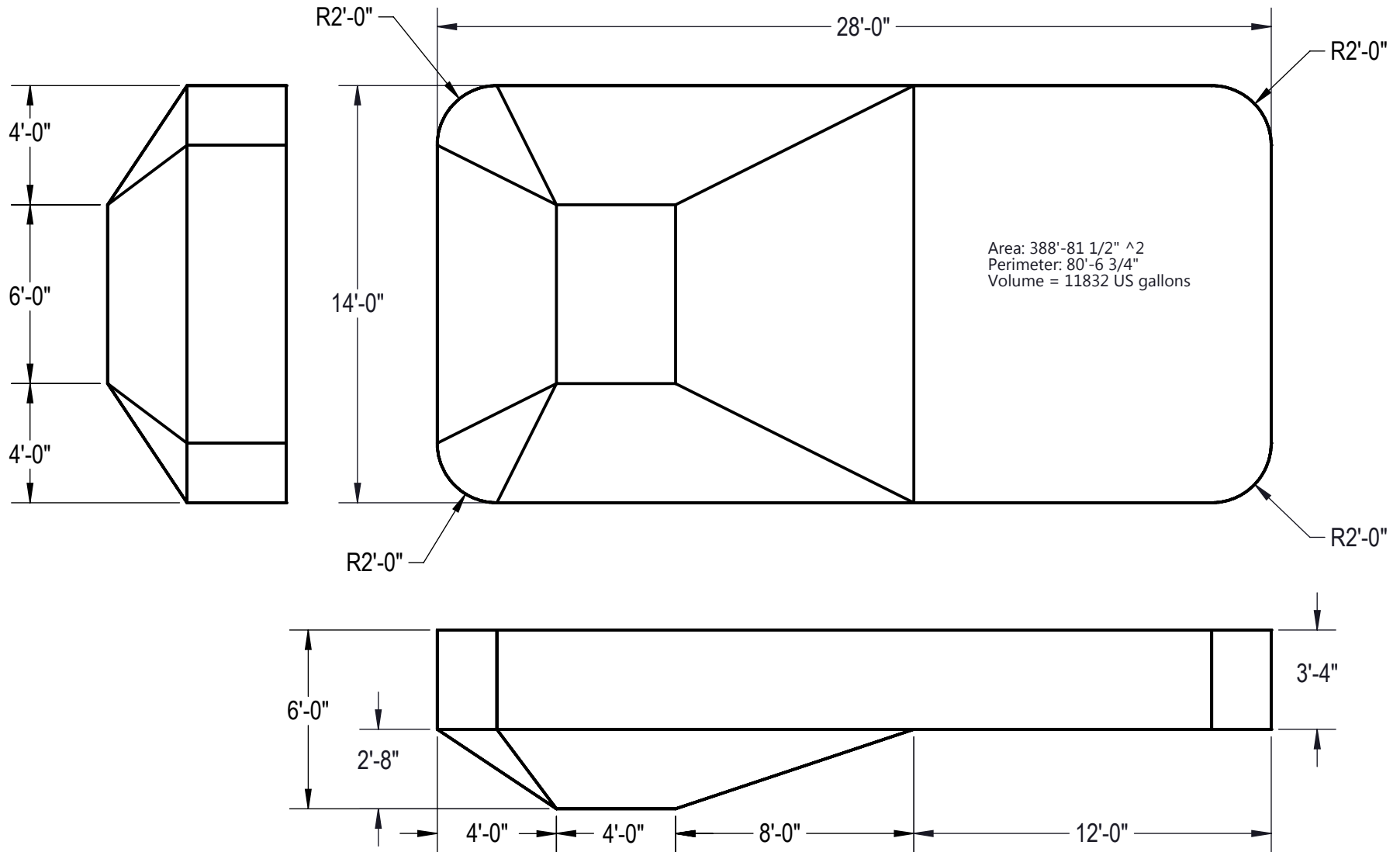

NOTES:

1. THESE ARE FINISHED DIMENSIONS READY FOR THE LINER.
2. DIMENSIONS ARE FROM INSIDE POOL PANELS.
3. THE IDEAL WATER LEVEL SHOULD BE TO THE MIDDLE OF THE SKIMMER OPENING(S).

EXCAVATION NOTES:

4. ROUGH EXCAVATION SHOULD BE 2" DEEPER IN EACH INSTANCE.
5. SOIL TO HAVE MINIMUM BEARING CAPACITY OF 1500 PSF.
6. LOCATE TOP OF POOL AT LEAST 6" ABOVE THE SURROUNDING LAND ELEVATION.
7. SEE "OVER DIG DETAIL" FOR EXCAVATION AROUND POOL.
8. FILL VOIDS UNDER BASE OF PANELS AND TAMP WELL.
9. BACK FILL WITH NON-EXPANSIVE MATERIAL.
10. ANSI / APSP / ICC-5 FOR RESIDENTIAL POOLS, 2003-2007 BOCA CODE SECTION 421.

IMPORTANT NOTES:

11. THIS DOCUMENT IS FOR ILLUSTRATIVE PURPOSES ONLY. THE DEALER OR CONTRACTOR WHO SELLS OR INSTALLS YOUR POOL IS AN INDEPENDENT CONTRACTOR AND IS NOT AN AGENT OF THE MANUFACTURER. THE CONSTRUCTION METHODS ILLUSTRATED HERE ARE SUGGESTIONS AND APPLY ONLY TO NORMAL GROUND CONDITIONS. THERE MAY BE ADDITIONAL PRECAUTIONS AND/OR METHODS OF CONSTRUCTION. PROPER INSTALLATION IS THE RESPONSIBILITY OF THE DEALER/BUILDER/CONTRACTOR.

ENGINEERING DRAWING NUMBER: 00004169	WEIGHT:	UNLESS OTHERWISE SPECIFIED DIMENSIONS ARE IN INCHES TOLERANCES DECIMALS: X ± .1 XX ± .01 XXX ± .001 XXXX ± .0005 ANGULAR: X ± 0.5 THIRD ANGLE PROJECTION	DESIGNED BY:	CREATION DATE:	HYDRA POOLS
	VOLUME: Inch ³		RCOLBOCH	6/4/2013	
	COLOR:		DETAILED BY:	DETAILED DATE:	
	HEAT TREAT:		JBOSSERDET	10/5/2012	
NA FINISH:	LAST REVISED BY:	LAST REVISED DATE:	TITLE:	LAYOUT, RECTANGLE, 14' X 28', 6' DEEP, 2' RADIUS, 500 SERIES	
NA TEXTURE:	jbosserdet	12/23/2014	PART NUMBER:		
NA	MATERIAL:		SCALE:	SIZE:	
			1:96	A	
			SHEET:		
			2 OF 2		