

| REVISION HISTORY | | | | |
|------------------|---|-----------|--------|------------|
| REV. | DESCRIPTION | DATE | ECO | BY |
| A | 2014 POLYMER DIG BOOK | 9/6/2013 | | RCOLBOCH |
| B | UPDATED TAG DATA TO INCLUDE COPING LENGTHS. | 1/29/2015 | 391702 | JBOSSERDET |

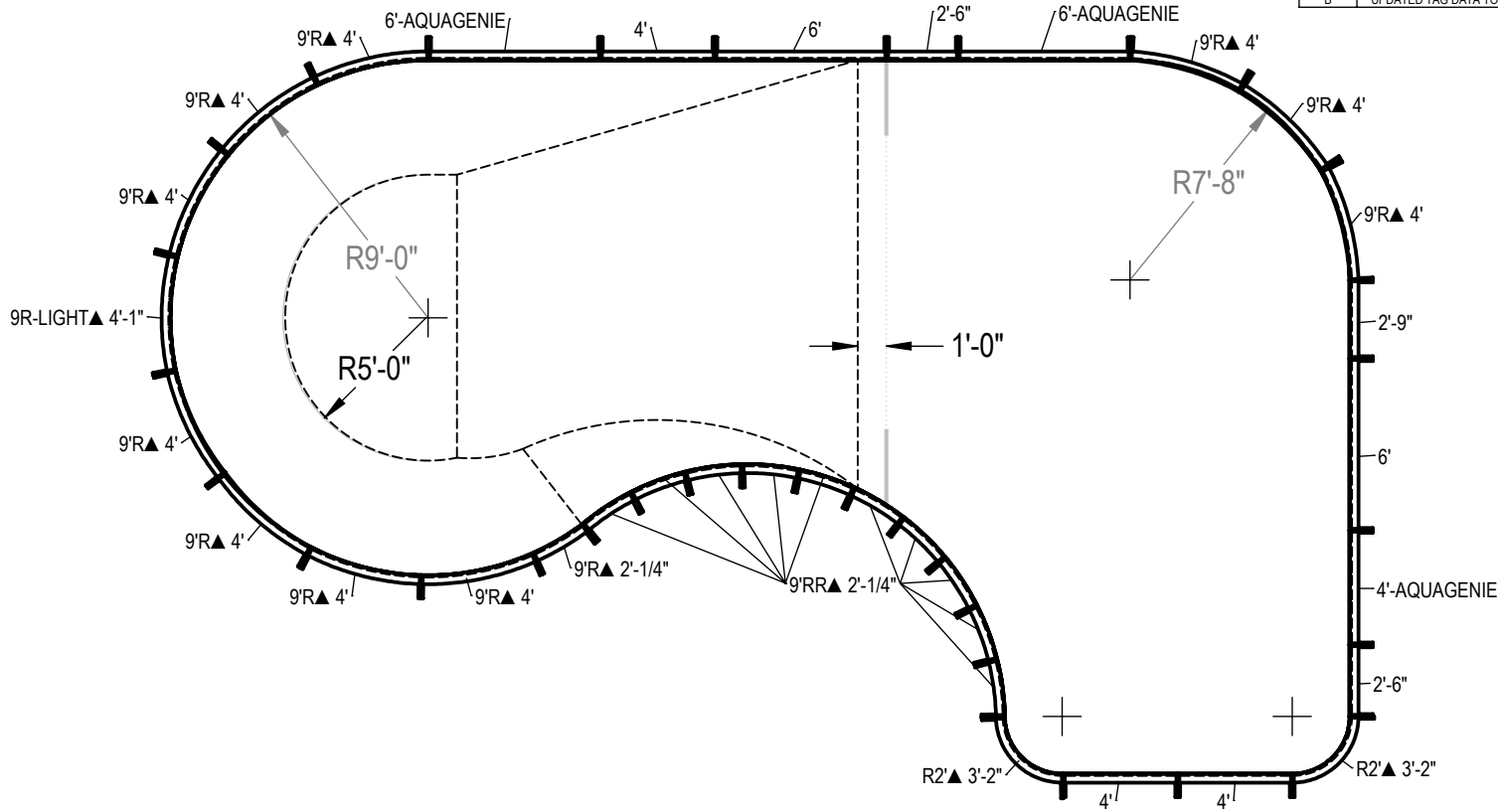

| ITEM | FILE NAME | DESCRIPTION | CUSTOMER DRAWING # | VENDOR PART # | QTY. | VENDOR NAME | MATERIAL |
|------|-------------------------------|---|--------------------|---------------|------|-----------------|----------------|
| 1 | BRACE | BRACE, 4 TAB, HYDRA - 100 SERIES | HP199 | HP199 | 35 | HYDRA POOLS | PS |
| 2 | INSERT, 5° WEDGE | INSERT, 5° WEDGE | HP226 | HP226 | 4 | HYDRA POOLS, IA | PP Homopolymer |
| 3 | PANEL, 2'-9 IN LONG | PANEL, 2'-9" LONG - 100 SERIES | HP117 | HP117 | 1 | HYDRA POOLS | PS |
| 4 | PANEL, 2'-6 IN LONG | PANEL, 2'-6" LONG - 100 SERIES | HP183S | HP183S | 2 | HYDRA POOLS | PS |
| 5 | PANEL, 2' RADIUS | PANEL, 2' RADIUS - 100 SERIES | HP152M | HP152M | 2 | HYDRA POOLS | PS |
| 6 | PANEL, 4' LONG | PANEL, 4' LONG - 100 SERIES | HP104 | HP104 | 3 | HYDRA POOLS | PS |
| 7 | PANEL, 4' LONG WITH AQUAGENIE | PANEL, 4' LONG WITH AQUA GENIE - 100 SERIES | HP104A | HP104A | 1 | HYDRA POOLS | PS |
| 8 | PANEL, 6' LONG | PANEL, 6' LONG - 100 SERIES | HP106 | HP106 | 2 | HYDRA POOLS | PS |
| 9 | PANEL, 6' LONG WITH AQUAGENIE | PANEL, 6' LONG WITH AQUA GENIE - 100 SERIES | HP106A | HP106A | 2 | HYDRA POOLS | PS |
| 10 | PANEL, 9' RADIUS WITH LIGHT | PANEL, 9' RADIUS WITH LIGHT - 100 SERIES | HP159LL | HP159LL | 1 | HYDRA POOLS | PS |
| 11 | PANEL, 9' RADIUS, 2' LONG | PANEL, 9' RADIUS, 2' LONG, INSERT OVAL - 100 SERIES | HP110 | HP110 | 1 | HYDRA POOLS | PS |
| 12 | PANEL, 9' RADIUS, 4' LONG | PANEL, 9' RADIUS, 4' LONG - 100 SERIES | HP159 | HP159 | 10 | HYDRA POOLS | PS |
| 13 | PANEL, 9' REVERSE RADIUS | PANEL, 9' REVERSE RADIUS - 100 SERIES | HP119N | HP119N | 10 | HYDRA POOLS | PS |

NOTES:

1. THESE ARE FINISHED DIMENSIONS READY FOR THE LINER. DIMENSIONS ARE FROM INSIDE POOL PANELS.
2. THE IDEAL WATER LEVEL SHOULD BE TO THE MIDDLE OF THE SKIMMER OPENING(S).

EXCAVATION NOTES:

3. ROUGH EXCAVATION SHOULD BE 2" DEEPER IN EACH INSTANCE.
4. SOIL TO HAVE MINIMUM BEARING CAPACITY OF 1500 PSF.
5. LOCATE TOP OF POOL AT LEAST 6" ABOVE THE SURROUNDING LAND ELEVATION.
6. SEE "OVER DIG DETAIL" FOR EXCAVATION AROUND POOL.
7. FILL FOLDS UNDER BASE OF PANELS AND TAMP WELL.
8. BACK FILL WITH NON-EXPANSIVE MATERIAL.
9. ANSII / APSP / ICC-5 FOR RESIDENTIAL POOLS, 2003-2007 BOCA CODE SECTION 421.

IMPORTANT NOTES:

10. THIS DOCUMENT IS FOR ILLUSTRATIVE PURPOSES ONLY. THE DEALER OR CONTRACTOR WHO SELLS OR INSTALLS YOUR POOL IS AN INDEPENDENT CONTRACTOR AND IS NOT AN AGENT OF THE MANUFACTURER. THE CONSTRUCTION METHODS ILLUSTRATED HERE ARE SUGGESTIONS AND APPLY ONLY TO NORMAL GROUND CONDITIONS. THERE MAY BE ADDITIONAL PRECAUTIONS AND/OR METHODS OF CONSTRUCTION. PROPER INSTALLATION IS THE RESPONSIBILITY OF THE DEALER/BUILDER/CONTRACTOR.

| | | | | | |
|--|------------------------------|--|--------------------|--|--------------------|
| ENGINEERING DRAWING NUMBER: 00005082 | WEIGHT: | UNLESS OTHERWISE SPECIFIED DIMENSIONS ARE IN INCHES TOLERANCES DECIMALS: X ± .1 XX ± .01 XXX ± .005 | DESIGNED BY: | CREATION DATE: | HYDRA POOLS |
| | VOLUME: Inch ³ | | RCOLBOCH | 9/6/2013 | |
| | COLOR: | DETAILED BY: | DETAILED DATE: | TITLE: LAYOUT, 25' X 41'-3", NAUTILUS, LEFT, 8' DEEP, 100 SERIES | |
| | HEAT TREAT: | JBOSSERDET | 10/5/2012 | | |
| FINISH: | ANGULAR: X ± 0.5 | LAST REVISED BY: | LAST REVISED DATE: | PART NUMBER: | |
| TEXTURE: | THIRD ANGLE PROJECTION | Jbosserdet | 1/29/2015 | 10970 | |
| | | MATERIAL: | | SCALE: 1:192 | SIZE: A |
| | | | | SHEET: 1 OF 6 | |

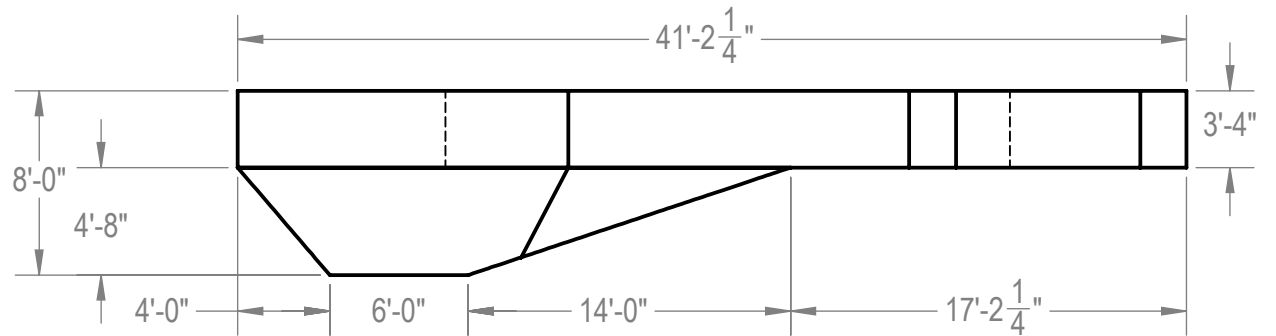
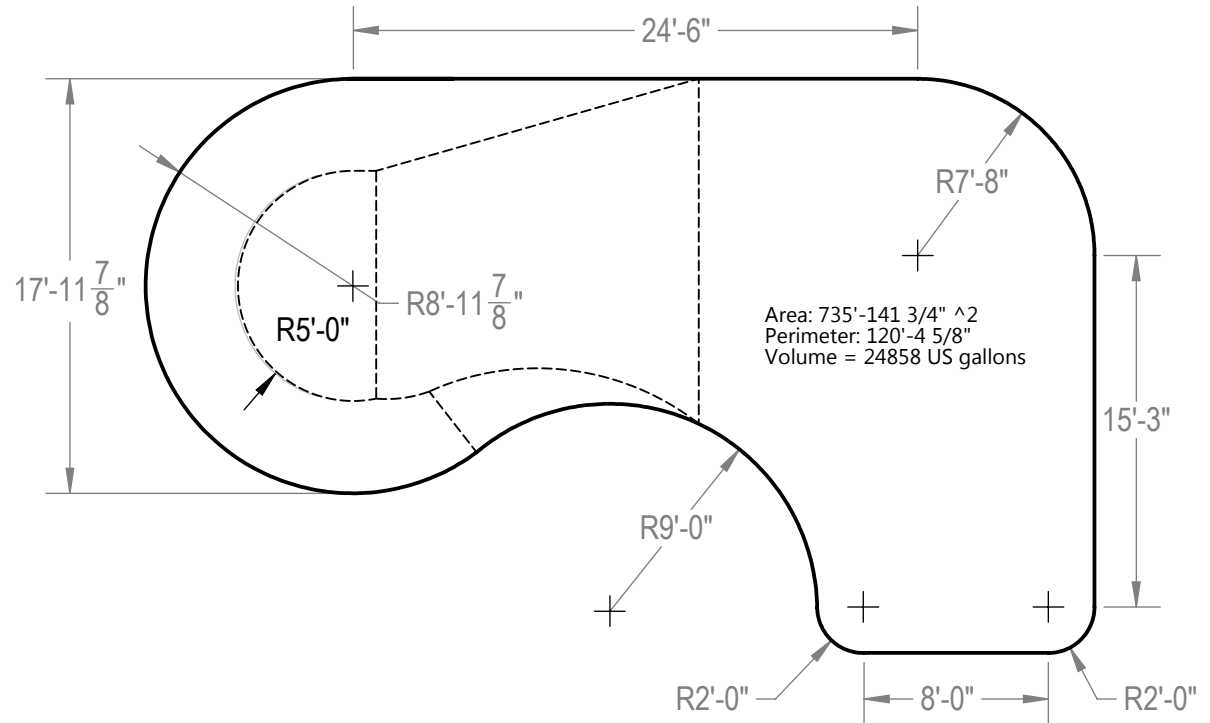
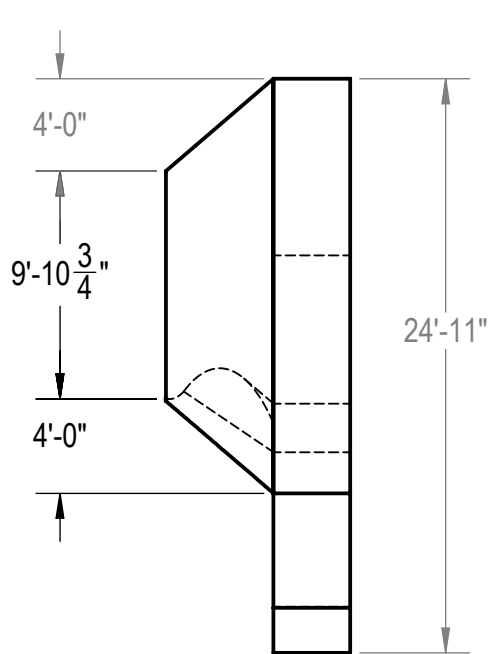

NOTES:

1. THESE ARE FINISHED DIMENSIONS READY FOR THE LINER.
2. DIMENSIONS ARE FROM INSIDE POOL PANELS.
3. THE IDEAL WATER LEVEL SHOULD BE TO THE MIDDLE OF THE SKIMMER OPENING(S).

EXCAVATION NOTES:

4. ROUGH EXCAVATION SHOULD BE 2" DEEPER IN EACH INSTANCE.
5. SOIL TO HAVE MINIMUM BEARING CAPACITY OF 1500 PSF.
6. LOCATE TOP OF POOL AT LEAST 6" ABOVE THE SURROUNDING LAND ELEVATION.
7. SEE "OVER DIG DETAIL" FOR EXCAVATION AROUND POOL.
8. FILL VOIDS UNDER BASE OF PANELS AND TAMP WELL.
9. BACK FILL WITH NON-EXPANSIVE MATERIAL.
10. ANSI / APSP / ICC-5 FOR RESIDENTIAL POOLS, 2003-2007 BOCA CODE SECTION 421.

IMPORTANT NOTES:

11. THIS DOCUMENT IS FOR ILLUSTRATIVE PURPOSES ONLY. THE DEALER OR CONTRACTOR WHO SELLS OR INSTALLS YOUR POOL IS AN INDEPENDENT CONTRACTOR AND IS NOT AN AGENT OF THE MANUFACTURER. THE CONSTRUCTION METHODS ILLUSTRATED HERE ARE SUGGESTIONS AND APPLY ONLY TO NORMAL GROUND CONDITIONS. THERE MAY BE ADDITIONAL PRECAUTIONS AND/OR METHODS OF CONSTRUCTION. PROPER INSTALLATION IS THE RESPONSIBILITY OF THE DEALER/BUILDER/CONTRACTOR.

| | | | | | | |
|--|--|---|---|--|---|---|
| ENGINEERING DRAWING NUMBER: 00005082 | WEIGHT: 207448.623 lbs VOLUME: 5742159.743 Inch ³ | UNLESS OTHERWISE SPECIFIED DIMENSIONS ARE IN INCHES TOLERANCES DECIMALS: X ± .1 XX ± .01 XXX ± .001 XXXX ± .0005 ANGULAR: X ± 0.5 THIRD ANGLE PROJECTION | DESIGNED BY: THARKENRIDER CREATION DATE: 1/10/2014 | HYDRA POOLS | | |
| | COLOR: NA HEAT TREAT: NA FINISH: NA TEXTURE: NA | | DETAILED BY: JBOSSERDET DETAILED DATE: 10/5/2012 | | | LAST REVISED BY: jbosserdet LAST REVISED DATE: 1/29/2015 |
| | TITLE: LAYOUT, 25' X 41'-3", NAUTILUS, LEFT, 8' DEEP, 100 SERIES | | | PART NUMBER: <div style="font-size: 2em; font-weight: bold;">10970</div> | | |
| | | | | SCALE: 1:192 SHEET: 2 OF 6 | SIZE: <div style="font-size: 2em; font-weight: bold;">A</div> | |

| | |
|------|-------------|
| A-S1 | 27'-2" |
| B-S1 | 20'-4 7/8" |
| A-S2 | 32'-3 5/8" |
| B-S2 | 27'- 7/8" |
| A-S3 | 14'-9 1/8" |
| B-S3 | 34'-10 3/4" |
| A-S4 | 21'-3 3/4" |
| B-S4 | 38'-1 1/2" |

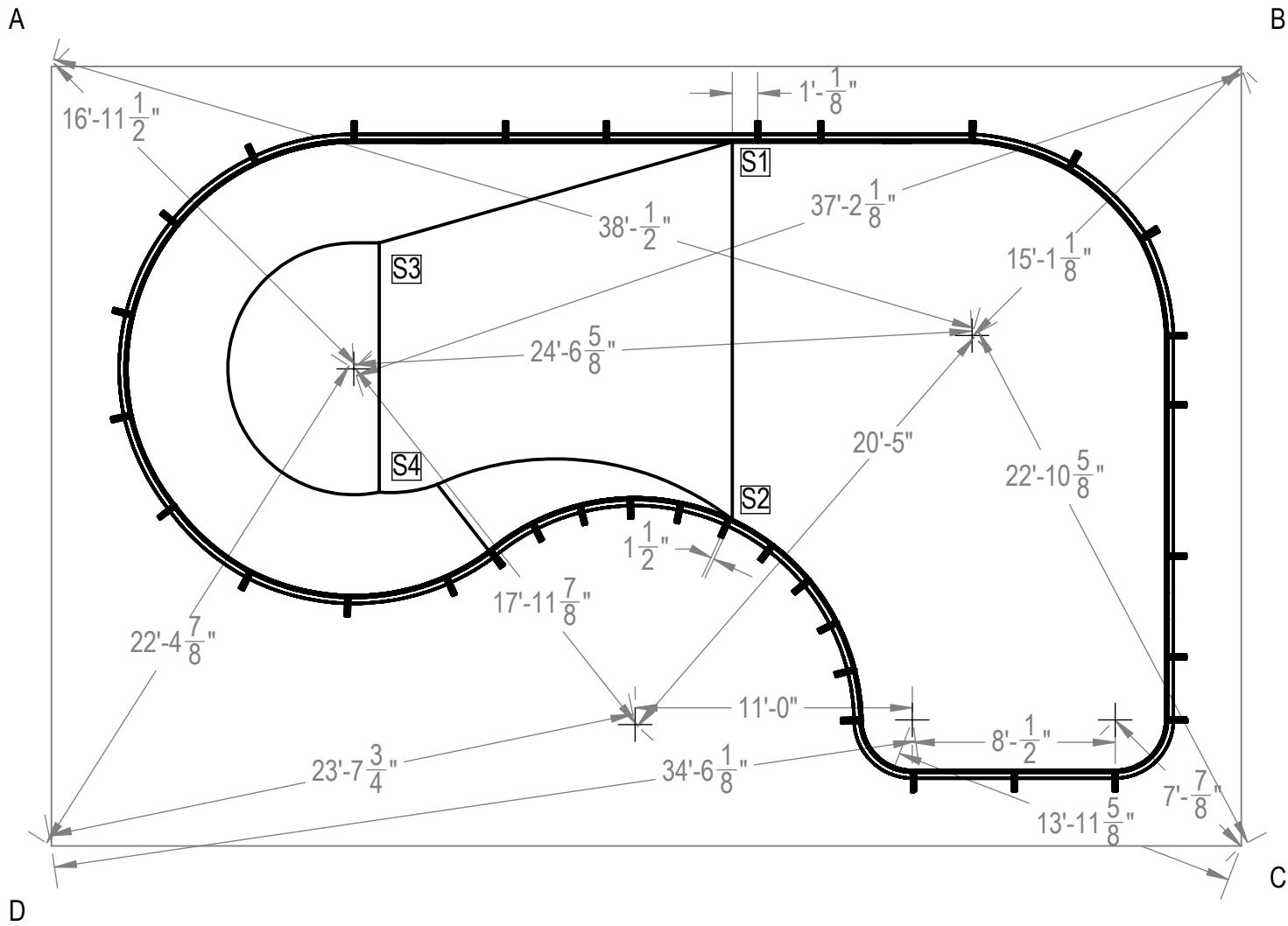

| | | | | | | |
|--|------------------------------|---|-------------------------------|---------------------------------|--------------------|--|
| ENGINEERING DRAWING NUMBER: 00005082 | WEIGHT: lbs | UNLESS OTHERWISE SPECIFIED DIMENSIONS ARE IN INCHES TOLERANCES DECIMALS: X ± .1 XX ± .01 XXX ± .001 XXXX ± .0005 ANGULAR: X ± 0.5 THIRD ANGLE PROJECTION | DESIGNED BY: RCOLBOCH | CREATION DATE: 9/6/2013 | HYDRA POOLS | |
| | VOLUME: Inch ³ | | DETAILED BY: JBOSSEDET | DETAILED DATE: 10/5/2012 | | |
| | COLOR: | | LAST REVISED BY: jbossedet | LAST REVISED DATE: 1/29/2015 | | TITLE: LAYOUT, 25' X 41'-3", NAUTILUS, LEFT, 8' DEEP, 100 SERIES |
| | HEAT TREAT: | | MATERIAL: | PART NUMBER: | | |
| | FINISH: | | | 10970 | | |
| TEXTURE: | | SCALE: 1:192 | SIZE: A | | | |
| | | | | SHEET: 3 OF 6 | | |

| | A | B | C | D |
|----|-------------|-------------|-------------|-------------|
| 1 | 10'-4 3/4" | 45'- 1/4" | 48'-8 1/2" | 21'-3 5/8" |
| 2 | 8'- 3/4" | 42'-7 5/8" | 48'-9 3/4" | 25'-1 3/8" |
| 3 | 9'- 1/8" | 39'-2 3/4" | 47'-6" | 28'-3" |
| 4 | 12'-4 5/8" | 35'-3 5/8" | 44'-10 7/8" | 30'-4 3/4" |
| 5 | 18'-3 1/8" | 29'-3 7/8" | 40'-4 1/2" | 33'-2 3/4" |
| 6 | 22'-2 5/8" | 25'-4 1/8" | 37'-7 1/8" | 35'-6 5/8" |
| 7 | 28'-2 1/8" | 19'-4 7/8" | 33'-10 3/8" | 39'-6 5/8" |
| 8 | 30'-7 7/8" | 16'-11 1/4" | 32'-6 1/4" | 41'-4 1/4" |
| 9 | 36'-7 5/8" | 11'-1" | 29'-10 5/8" | 45'-11 5/8" |
| 10 | 40'-6 3/8" | 8'-0" | 27'-8 1/8" | 48'-5 1/8" |
| 11 | 43'-8 5/8" | 7'-11 3/8" | 24'-4 5/8" | 49'-5" |
| 12 | 45'-5 3/8" | 11'-1 3/8" | 20'-5 5/8" | 48'-7 1/4" |
| 13 | 46'-2 1/8" | 13'-9" | 17'-9 1/8" | 47'-6 1/4" |
| 14 | 48'-3 1/8" | 19'-7 3/4" | 11'-10 5/8" | 45'-7 7/8" |
| 15 | 50'- 1/8" | 23'-7 3/8" | 8'- 7/8" | 44'-9 3/4" |
| 16 | 51'-2 3/4" | 26'-1 1/8" | 5'-10" | 44'-5 5/8" |
| 17 | 50'-7" | 28'-4 3/8" | 5'-10" | 42'-3 1/2" |
| 18 | 47'-3 5/8" | 29'-4" | 9'-5 7/8" | 38'-3 5/8" |
| 19 | 44'-1 5/8" | 30'-9 5/8" | 13'-4 1/8" | 34'-3 3/4" |
| 20 | 41'-3 3/4" | 30'-0" | 15'-10" | 32'-6 3/8" |
| 21 | 39'-10 1/4" | 28'-4 7/8" | 16'-9 7/8" | 32'-7 5/8" |
| 22 | 38'-2 1/8" | 27'-2 7/8" | 18'-3 3/4" | 32'-5" |
| 23 | 36'-3 3/4" | 26'-7 1/8" | 20'-1 3/8" | 31'-10 1/2" |
| 24 | 34'-3 7/8" | 26'-6 1/2" | 22'-1 1/8" | 31'- 1/8" |
| 25 | 32'-3 5/8" | 27'- 7/8" | 24'-1 1/4" | 29'-10 3/8" |
| 26 | 30'-4 3/8" | 28'-1 7/8" | 26'- 3/4" | 28'-5 3/8" |
| 27 | 28'-7 5/8" | 29'-7 7/8" | 27'-10 5/8" | 26'-9 1/2" |
| 28 | 27'-2 3/4" | 31'-5 1/2" | 29'-6 1/8" | 24'-11 1/2" |
| 29 | 26'-3 3/8" | 33'-5 1/8" | 30'-10 7/8" | 22'-11 7/8" |
| 30 | 25'-10 3/4" | 35'-5 3/4" | 32'- 1/2" | 20'-11 1/4" |
| 31 | 25'-6 3/4" | 37'-5 1/2" | 33'-3 5/8" | 18'-11 1/2" |
| 32 | 24'- 5/8" | 41'-2 1/8" | 36'-9 1/2" | 15'-4 3/4" |
| 33 | 21'-6 1/4" | 44'- 7/8" | 40'-9 1/8" | 13'-5 3/4" |
| 34 | 18'-1" | 45'-8 1/2" | 44'-4 1/2" | 14'-4 5/8" |
| 35 | 14'-2 3/8" | 46'-1 3/8" | 47'-2 3/8" | 17'-4 5/8" |

| | |
|-----|------------|
| A-B | 47'-2 1/4" |
| B-C | 30'-11" |
| A-C | 56'-5" |

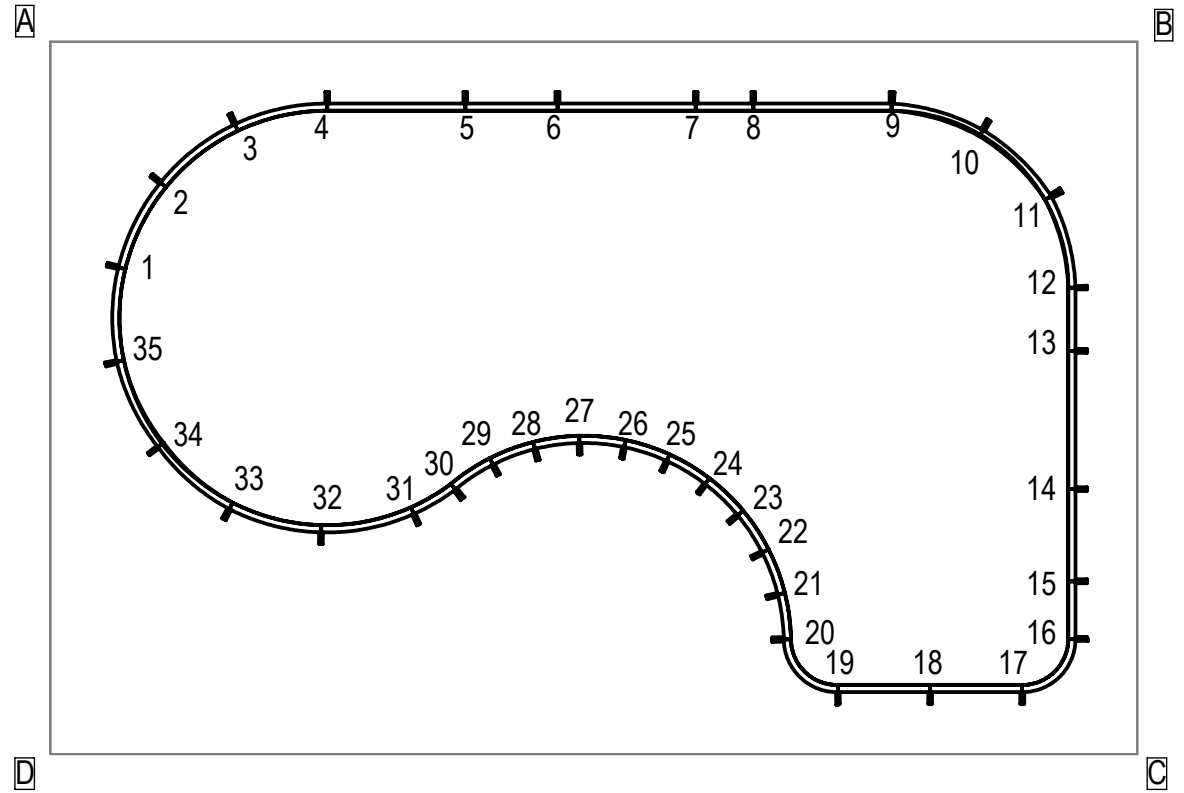

ENGINEERING DRAWING NUMBER:
00005082

| | |
|------------------------------|---|
| WEIGHT: lbs | UNLESS OTHERWISE SPECIFIED DIMENSIONS ARE IN INCHES TOLERANCES DECIMALS: X ± .1 XX ± .01 XXX ± .001 XXXX ± .0005 ANGULAR: X ± 0.5 THIRD ANGLE PROJECTION |
| VOLUME: Inch ³ | |
| COLOR: | |
| HEAT TREAT: | |
| FINISH: | |
| TEXTURE: | |

| | |
|-------------------------------|---------------------------------|
| DESIGNED BY: RCOLBOCH | CREATION DATE: 9/6/2013 |
| DETAILED BY: JBOSSEDET | DETAILED DATE: 10/5/2012 |
| LAST REVISED BY: jbossedet | LAST REVISED DATE: 1/29/2015 |
| MATERIAL: | |

| | |
|--|-------------------|
| HYDRA POOLS | |
| TITLE: LAYOUT, 25' X 41'-3", NAUTILUS, LEFT, 8' DEEP, 100 SERIES | |
| PART NUMBER: | 10970 |
| SCALE: 1:192 | SIZE: A |
| SHEET: 4 OF 6 | |

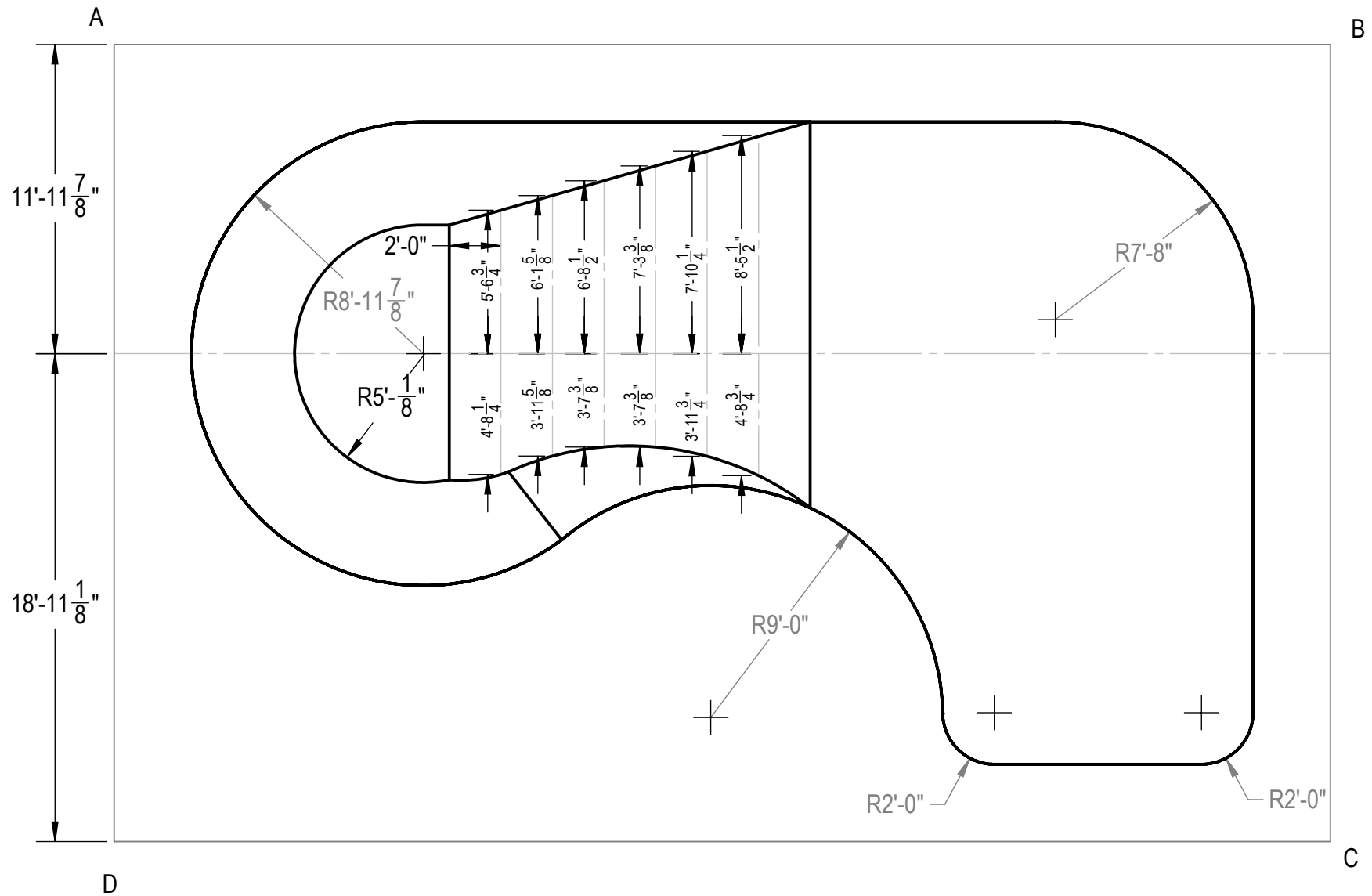

| | | | | | | |
|--|---------------------------------------|---|-------------------------------|----------------------------------|--|-------------------|
| ENGINEERING DRAWING NUMBER: 00005082 | WEIGHT: 207448.623 lbs | UNLESS OTHERWISE SPECIFIED DIMENSIONS ARE IN INCHES TOLERANCES DECIMALS: X ± .1 XX ± .01 XXX ± .001 XXXX ± .0005 ANGULAR: X ± 0.5 THIRD ANGLE PROJECTION | DESIGNED BY: THARKENRIDER | CREATION DATE: 1/10/2014 | HYDRA POOLS TITLE: LAYOUT, 25' X 41'-3", NAUTILUS, LEFT, 8' DEEP, 100 SERIES | |
| | VOLUME: 5742159.743 Inch ³ | | DETAILED BY: JBOSSEDET | DETAILED DATE: 10/5/2012 | | |
| | COLOR: NA | | LAST REVISED BY: jbossedet | LAST REVISED DATE: 1/29/2015 | | |
| | HEAT TREAT: NA | | MATERIAL: Water | PART NUMBER: 10970 | SCALE: 1:192 | SIZE: A |
| | FINISH: NA | | | | SHEET: 5 OF 6 | |
| TEXTURE: NA | | | | | | |

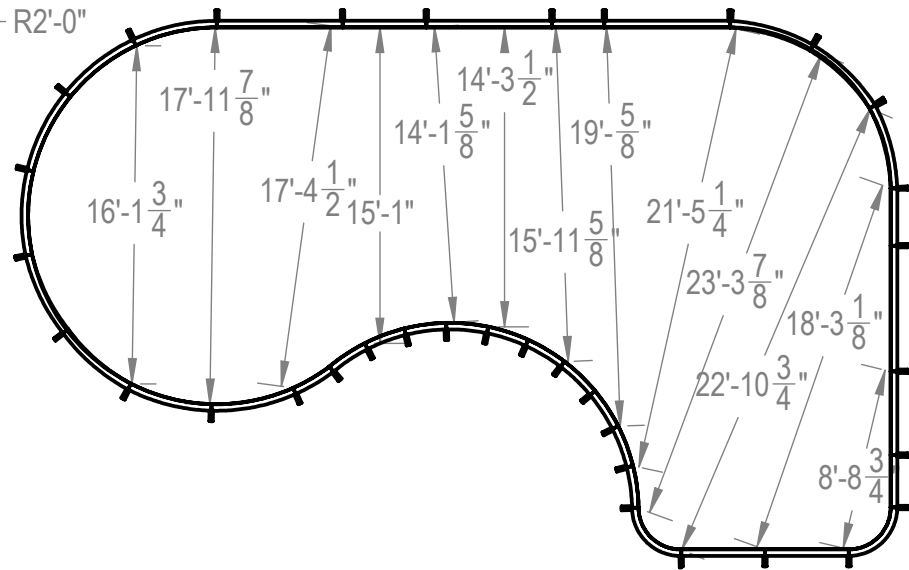
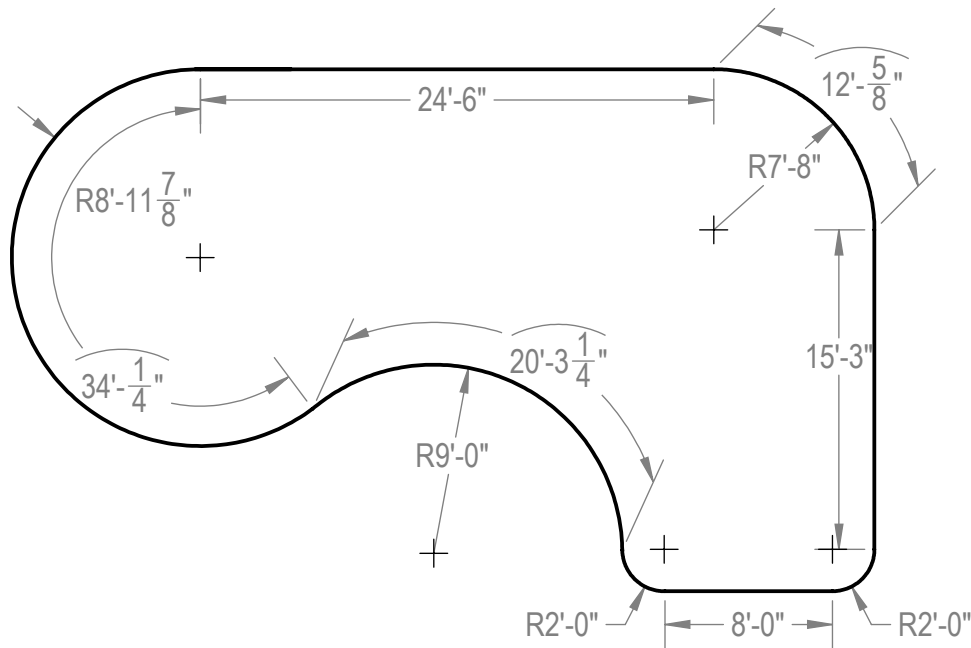

| | | | | | |
|--|-------------------|---|------------------|--------------------|---|
| ENGINEERING DRAWING NUMBER: 00005082 | WEIGHT: | UNLESS OTHERWISE SPECIFIED DIMENSIONS ARE IN INCHES TOLERANCES DECIMALS: X ± .1 XX ± .01 XXX ± .001 XXXX ± .0005 ANGULAR: X ± 0.5 THIRD ANGLE PROJECTION  | DESIGNED BY: | CREATION DATE: | HYDRA POOLS TITLE: LAYOUT, 25' X 41'-3", NAUTILUS, LEFT, 8' DEEP, 100 SERIES PART NUMBER: <div style="font-size: 2em; font-weight: bold; text-align: center;">10970</div> |
| | lbs | | RCOLBOCH | 9/6/2013 | |
| | VOLUME: | | DETAILED BY: | DETAILED DATE: | |
| | Inch ³ | | JBOSSERDET | 10/5/2012 | |
| | COLOR: | | LAST REVISED BY: | LAST REVISED DATE: | |
| | NA | | jbosserdet | 1/29/2015 | |
| HEAT TREAT: | MATERIAL: | | | | |
| NA | | | SCALE: | SIZE: | |
| FINISH: | | | 1:192 | A | |
| TEXTURE: | | | 6 OF 6 | | |
| NA | | | | | |