

REVISION HISTORY				
REV.	DESCRIPTION	DATE	ECO	BY
A	2014 POLYMER DIG BOOK	01/07/14	NONE	THARKENRIDER
B	UPDATED TAG DATA TO INCLUDE COPING LENGTHS.	1/26/2015	391702	JBOSSERDET

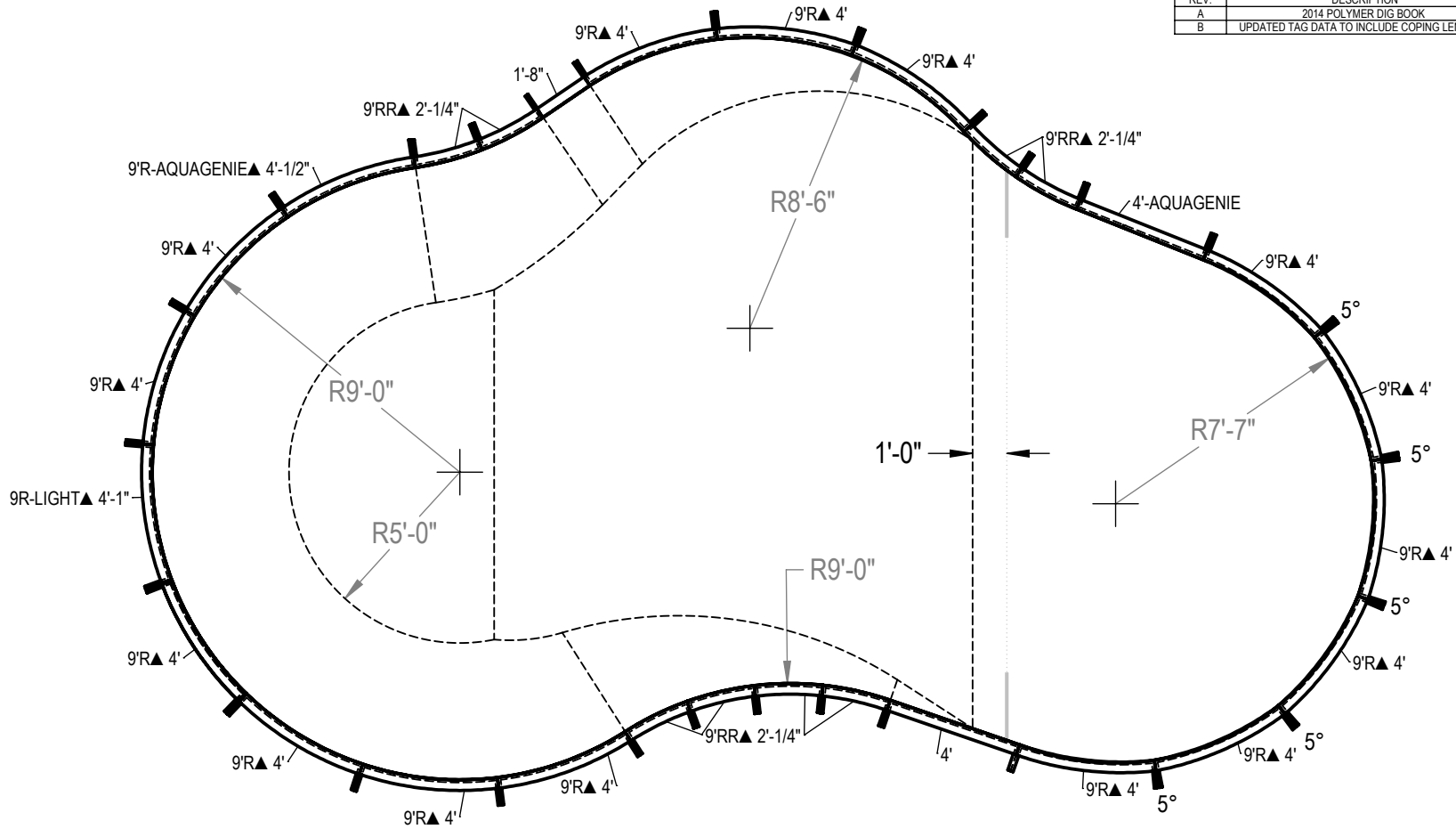

ITEM	FILE NAME	DESCRIPTION	CUSTOMER DRAWING #	VENDOR PART #	QTY.	VENDOR NAME	MATERIAL
1	BRACE	BRACE, 4 TAB, HYDRA - 100 SERIES	HP199	HP199	28	HYDRA POOLS	PS
2	INSERT, 5° WEDGE	INSERT, 5° WEDGE	HP226	HP226	5	HYDRA POOLS, IA	PP Homopolymer
3	PANEL, 1'-8 IN LONG	PANEL, 1'-8" LONG - 100 SERIES	HP116	HP116	1	HYDRA POOLS	PS
4	PANEL, 4' LONG	PANEL, 4' LONG - 100 SERIES	HP104	HP104	1	HYDRA POOLS	PS
5	PANEL, 4' LONG WITH AQUA GENIE	PANEL, 4' LONG WITH AQUA GENIE - 100 SERIES	HP104A	HP104A	1	HYDRA POOLS	PS
6	PANEL, 9' RADIUS WITH AQUA GENIE	PANEL, 9' RADIUS WITH AQUAGENIE - 100 SERIES	HP159A	HP159A	1	HYDRA POOLS	PS
7	PANEL, 9' RADIUS WITH LIGHT	PANEL, 9' RADIUS WITH LIGHT - 100 SERIES	HP159LL	HP159LL	1	HYDRA POOLS	PS
8	PANEL, 9' RADIUS, 4' LONG	PANEL, 9' RADIUS, 4' LONG - 100 SERIES	HP159	HP159	16	HYDRA POOLS	PS
9	PANEL, 9' REVERSE RADIUS	PANEL, 9' REVERSE RADIUS - 100 SERIES	HP119N	HP119N	8	HYDRA POOLS	PS

ENGINEERING DRAWING NUMBER: 00005034	WEIGHT:	UNLESS OTHERWISE SPECIFIED DIMENSIONS ARE IN INCHES TOLERANCES DECIMALS: X ± 0.1 XX ± 0.01 XXX ± 0.005 XXXX ± 0.0005 ANGULAR: X ± 0.5 THIRD ANGLE PROJECTION	DESIGNED BY:	CREATION DATE:	HYDRA POOLS LAYOUT, 21'-8" X 35'-9", LAGOON, LEFT, 8' DEEP, 100 SERIES
	lbs		RCOLBOCH	6/10/2013	
	VOLUME:		DETAILED BY:	DETAILED DATE:	
	Inch ³		JBOSSERDET	10/5/2012	
COLOR:	LAST REVISED BY:	LAST REVISED DATE:	PART NUMBER:	SCALE:	SIZE:
NA	Jbosserdet	1/26/2015	10929	1:192	A
HEAT TREAT:	MATERIAL:			SHEET:	
NA				1 OF 6	
FINISH:					
NA					
TEXTURE:					
NA					

- NOTES:**
- THESE ARE FINISHED DIMENSIONS READY FOR THE LINER.
 - DIMENSIONS ARE FROM INSIDE POOL PANELS.
 - THE IDEAL WATER LEVEL SHOULD BE TO THE MIDDLE OF THE SKIMMER OPENING(S).
- EXCAVATION NOTES:**
- ROUGH EXCAVATION SHOULD BE 2" DEEPER IN EACH INSTANCE.
 - SOIL TO HAVE MINIMUM BEARING CAPACITY OF 1500 PSF.
 - LOCATE TOP OF POOL AT LEAST 6" ABOVE THE SURROUNDING LAND ELEVATION.
 - SEE "OVER DIG DETAIL" FOR EXCAVATION AROUND POOL.
 - FILL VOIDS UNDER BASE OF PANELS AND TAMP WELL.
 - BACK FILL WITH NON-EXPANSIVE MATERIAL.
 - ANSI / APSP / ICC-5 FOR RESIDENTIAL POOLS, 2003-2007 BOCA CODE SECTION 421.
- IMPORTANT NOTES:**
- THIS DOCUMENT IS FOR ILLUSTRATIVE PURPOSES ONLY. THE DEALER OR CONTRACTOR WHO SELLS OR INSTALLS YOUR POOL IS AN INDEPENDENT CONTRACTOR AND IS NOT AN AGENT OF THE MANUFACTURER. THE CONSTRUCTION METHODS ILLUSTRATED HERE ARE SUGGESTIONS AND APPLY ONLY TO NORMAL GROUND CONDITIONS. THERE MAY BE ADDITIONAL PRECAUTIONS AND/OR METHODS OF CONSTRUCTION. PROPER INSTALLATION IS THE RESPONSIBILITY OF THE DEALER/BUILDER/CONTRACTOR.

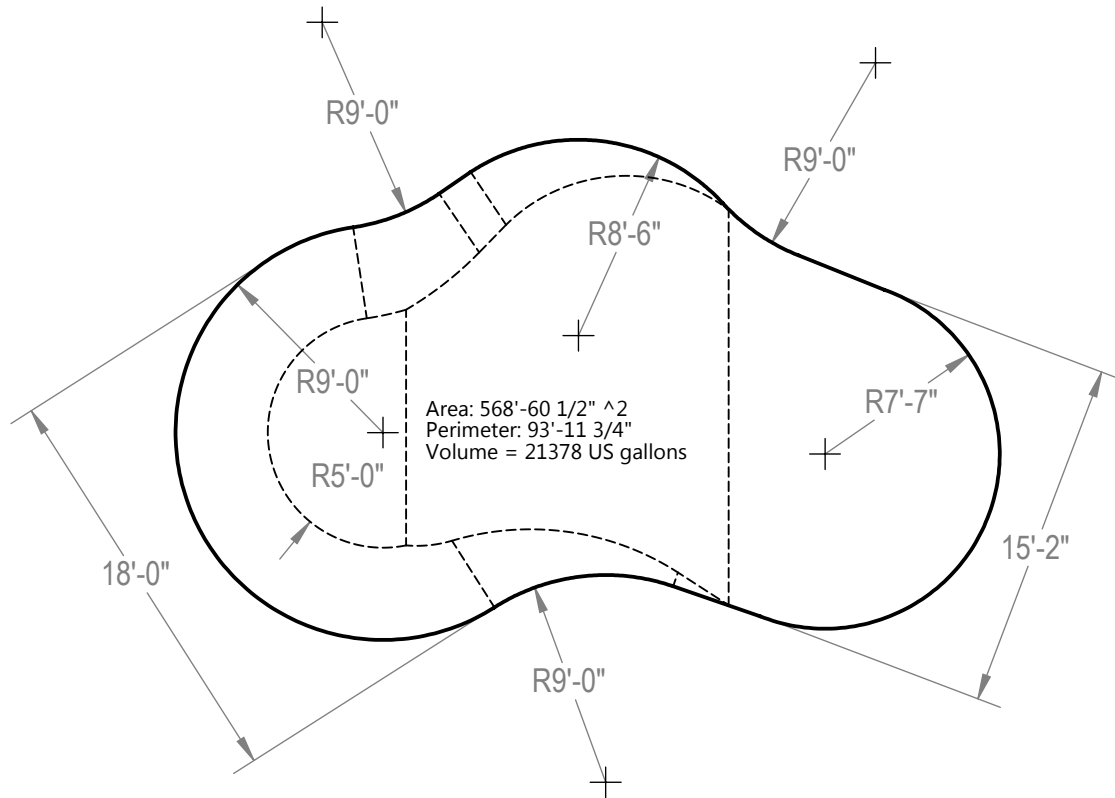
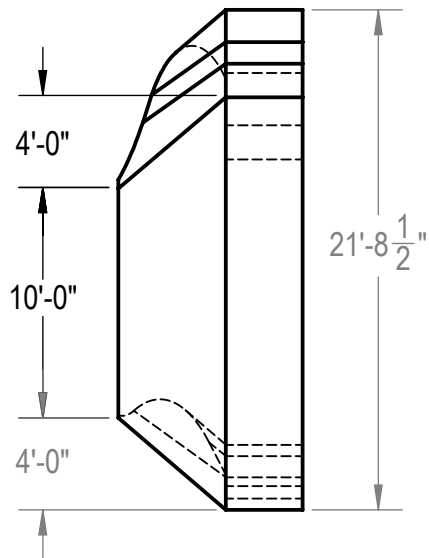

Area: 568'-60 1/2" ^2
 Perimeter: 93'-11 3/4"
 Volume = 21378 US gallons

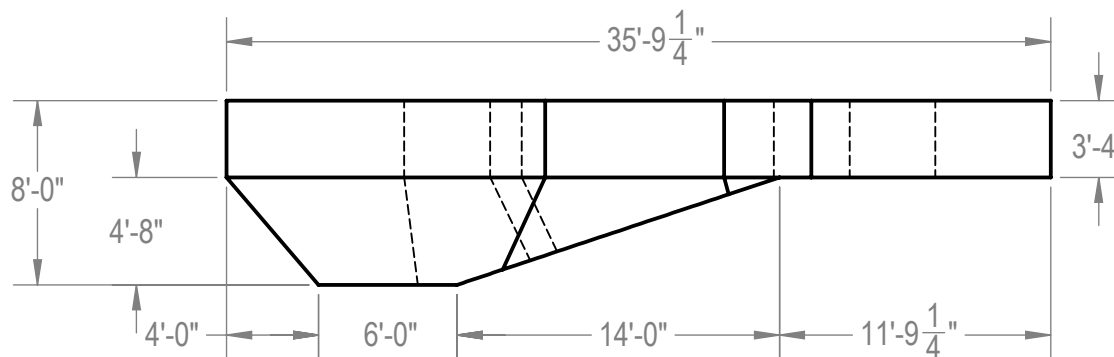

NOTES:

1. THESE ARE FINISHED DIMENSIONS READY FOR THE LINER.
2. DIMENSIONS ARE FROM INSIDE POOL PANELS.
3. THE IDEAL WATER LEVEL SHOULD BE TO THE MIDDLE OF THE SKIMMER OPENING(S).

EXCAVATION NOTES:

4. ROUGH EXCAVATION SHOULD BE 2" DEEPER IN EACH INSTANCE.
5. SOIL TO HAVE MINIMUM BEARING CAPACITY OF 1500 PSF.
6. LOCATE TOP OF POOL AT LEAST 6" ABOVE THE SURROUNDING LAND ELEVATION.
7. SEE "OVER DIG DETAIL" FOR EXCAVATION AROUND POOL.
8. FILL VOIDS UNDER BASE OF PANELS AND TAMP WELL.
9. BACK FILL WITH NON-EXPANSIVE MATERIAL.
10. ANSI / APSP / ICC-5 FOR RESIDENTIAL POOLS, 2003-2007 BOCA CODE SECTION 421.

IMPORTANT NOTES:

11. THIS DOCUMENT IS FOR ILLUSTRATIVE PURPOSES ONLY. THE DEALER OR CONTRACTOR WHO SELLS OR INSTALLS YOUR POOL IS AN INDEPENDENT CONTRACTOR AND IS NOT AN AGENT OF THE MANUFACTURER. THE CONSTRUCTION METHODS ILLUSTRATED HERE ARE SUGGESTIONS AND APPLY ONLY TO NORMAL GROUND CONDITIONS. THERE MAY BE ADDITIONAL PRECAUTIONS AND/OR METHODS OF CONSTRUCTION. PROPER INSTALLATION IS THE RESPONSIBILITY OF THE DEALER/BUILDER/CONTRACTOR.

ENGINEERING DRAWING NUMBER:
00005034

WEIGHT:	UNLESS OTHERWISE SPECIFIED
lbs	DIMENSIONS ARE IN INCHES
VOLUME:	TOLERANCES
Inch ³	DECIMALS: X ± .1
	XX ± .01
COLOR:	XXX ± .001
NA	XXXX ± .0005
HEAT TREAT:	
NA	ANGULAR: X ± 0.5
FINISH:	THIRD ANGLE PROJECTION
NA	
TEXTURE:	
NA	

DESIGNED BY:	RCOLBOCH	CREATION DATE:	6/10/2013
DETAILED BY:	JBOSSERDET	DETAILED DATE:	10/5/2012
LAST REVISED BY:	jbosserdet	LAST REVISED DATE:	1/26/2015
MATERIAL:			

HYDRA POOLS	
TITLE: LAYOUT, 21'-8" X 35'-9", LAGOON, LEFT, 8' DEEP, 100 SERIES	
PART NUMBER:	10929
SCALE:	1:192
SIZE:	A
SHEET:	2 OF 6

A-S1	27'-8"
B-S1	15'-11 1/2"
A-S2	35'-7 1/4"
B-S2	27'-6"
A-S3	16'-7 3/4"
B-S3	30'-7"
A-S4	24'-4 1/2"
B-S4	35'-4 3/4"

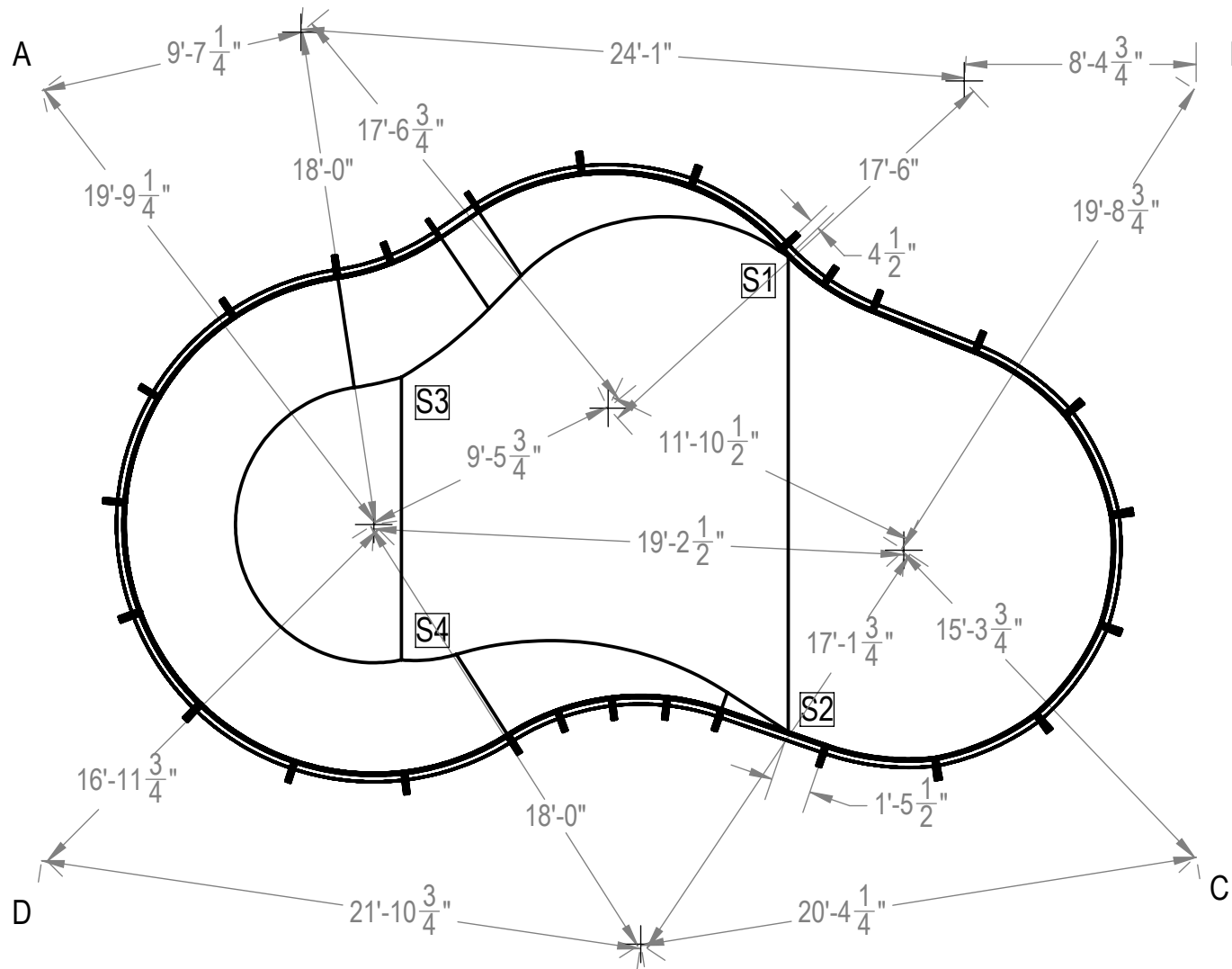

ENGINEERING DRAWING NUMBER: 00005034	WEIGHT:	UNLESS OTHERWISE SPECIFIED DIMENSIONS ARE IN INCHES TOLERANCES DECIMALS: X ± 0.1 XX ± 0.01 XXX ± 0.005 XXXX ± 0.0005 ANGULAR: X ± 0.5 THIRD ANGLE PROJECTION 	DESIGNED BY:	CREATION DATE:	HYDRA POOLS LAYOUT, 21'-8" X 35'-9", LAGOON, LEFT, 8' DEEP, 100 SERIES
	lbs		RCOLBOCH	6/10/2013	
	VOLUME:		DETAILED BY:	DETAILED DATE:	
	Inch ³		JBOSSERDET	10/5/2012	
	COLOR:		LAST REVISED BY:	LAST REVISED DATE:	
NA	jbosserdet	1/26/2015	PART NUMBER:	SCALE:	SIZE:
HEAT TREAT:	MATERIAL:		10929	1:192	A
NA				SHEET:	
FINISH:				3 OF 6	
TEXTURE:					
NA					

	A	B	C	D
1	15'-2 3/4"	41'-6"	40'-9 1/2"	13'-1 3/4"
2	11'-11"	39'-1 3/4"	41'- 1/4"	17'-1 1/4"
3	10'-9 1/2"	35'-9 1/4"	39'-10 1/2"	20'-8"
4	12'-8 1/4"	31'-9 3/4"	37'-5 1/4"	23'-5 3/4"
5	14'-1 1/2"	29'-9 1/2"	36'-1 3/4"	24'-10 1/2"
6	15'-4 3/4"	27'-10 1/4"	35'-3 3/4"	26'-7 1/2"
7	16'-5"	26'-4"	34'-10 3/4"	28'-1 3/4"
8	19'-9 1/4"	22'-5 1/4"	33'-2 1/2"	31'-5 1/2"
9	23'-8 3/4"	18'-7 1/2"	30'-4"	33'-8 1/2"
10	27'-4 1/4"	16'-1"	26'-7 1/4"	34'-7 1/4"
11	29'-1 3/4"	15'-3"	24'-8"	35'-0"
12	31'-1"	14'-2 1/2"	22'-11"	35'-11"
13	35'- 3/4"	12'-5 1/4"	19'-10 3/4"	38'-4 1/4"
14	38'-10"	12'-8 1/2"	16'-7 1/2"	40'-3 1/2"
15	41'-7 1/4"	15'-8 1/4"	12'-8 1/2"	40'-7"
16	42'-10 1/2"	19'-7 3/4"	9'-1"	39'-2 1/4"
17	42'-5 1/4"	23'-3 1/4"	7'-9 1/2"	36'-3 3/4"
18	40'-4"	25'-11"	10'-1 1/4"	32'-6 1/4"
19	36'-11 1/2"	27'-2 1/2"	13'-11 3/4"	28'-8"
20	33'-3"	28'-2 1/2"	17'-11 3/4"	25'-2"
21	31'-6 1/4"	29'-1 1/2"	20'-0"	23'-4 1/4"
22	30'-1 1/4"	30'-6"	21'-11 1/4"	21'-4 3/4"
23	29'-1 3/4"	32'-2 1/2"	23'-8 3/4"	19'-4 1/2"
24	28'-9"	34'-1 1/2"	25'-4"	17'-4 3/4"
25	27'-11"	37'-9 3/4"	28'-10"	13'-5 1/2"
26	25'-11"	40'-7 3/4"	32'-9 1/2"	9'-9 1/2"
27	22'-10 3/4"	42'-3 3/4"	36'-5 1/2"	7'-11 3/4"
28	19'-2 1/4"	42'-7 1/4"	39'-2 3/4"	9'-6 1/2"

A-B	41'-9 1/4"
B-C	27'-8 1/2"
A-C	50'-1 1/2"

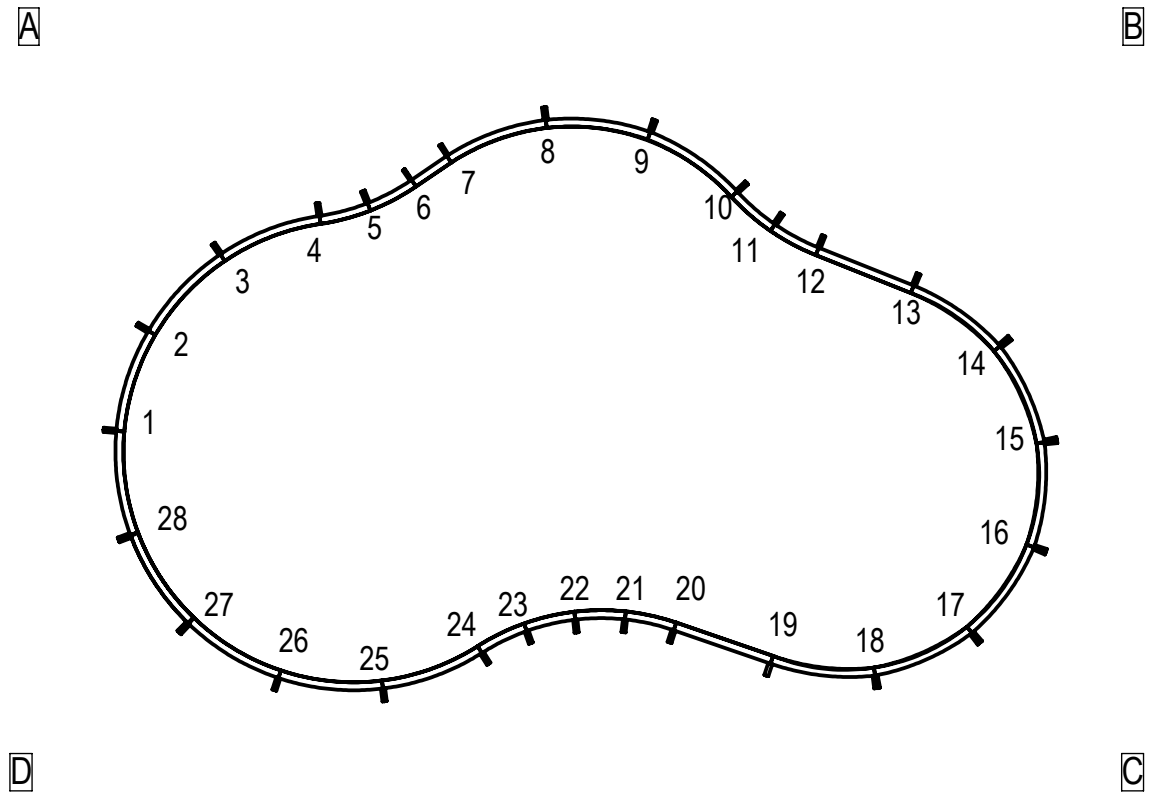



ENGINEERING DRAWING NUMBER:
00005034

WEIGHT:	UNLESS OTHERWISE SPECIFIED DIMENSIONS ARE IN INCHES TOLERANCES DECIMALS: X ± 0.1 XX ± 0.01 XXX ± 0.005 XXXX ± 0.0005 ANGULAR: X ± 0.5 THIRD ANGLE PROJECTION
lbs	
VOLUME:	
Inch ³	
COLOR:	
HEAT TREAT:	
FINISH:	
TEXTURE:	
NA	
NA	
NA	
NA	

DESIGNED BY:	RCOLBOCH
CREATION DATE:	6/10/2013
DETAILED BY:	JBOSSERDET
DETAILED DATE:	10/5/2012
LAST REVISED BY:	jbossdet
LAST REVISED DATE:	1/26/2015
MATERIAL:	

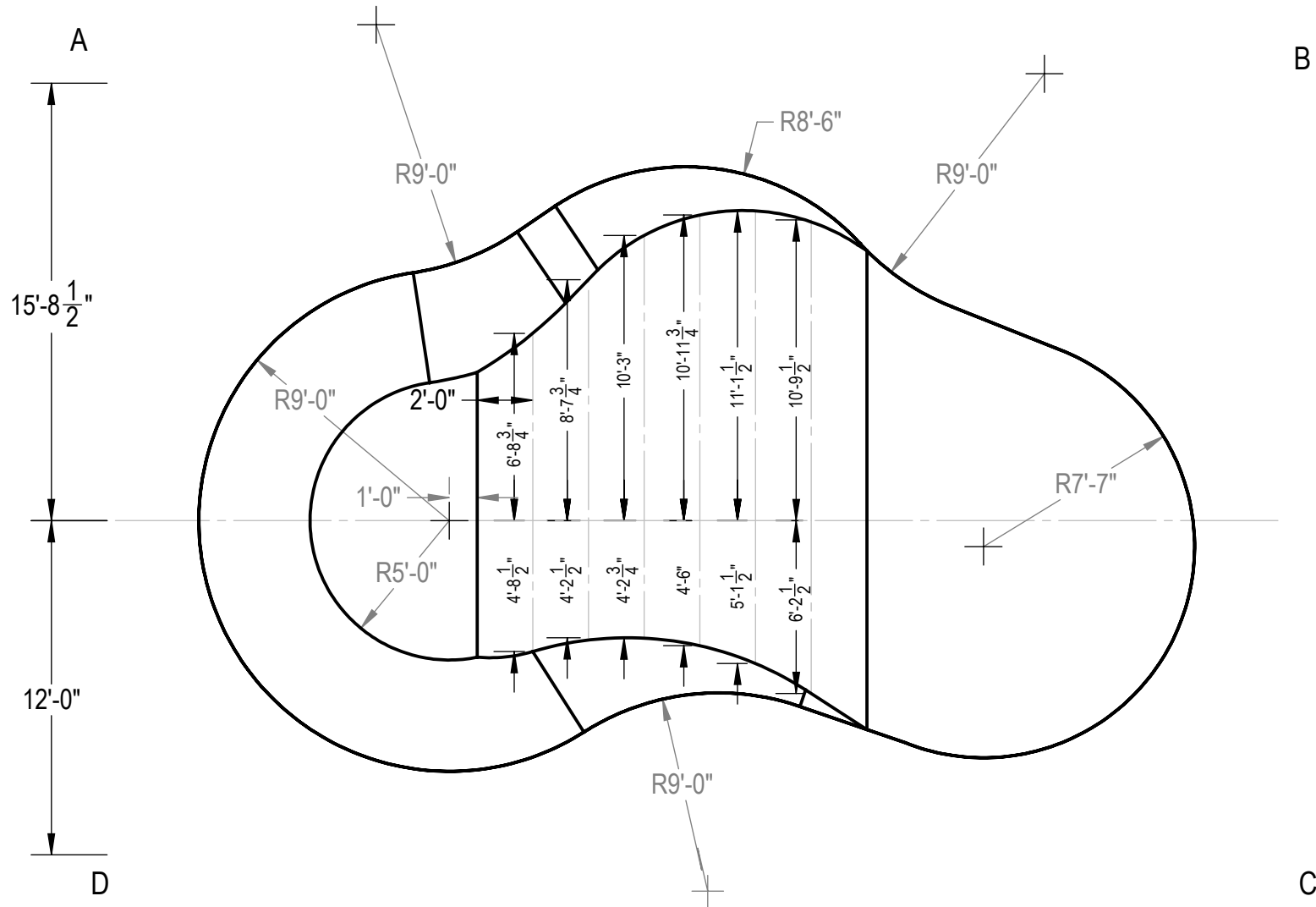
HYDRA POOLS	
TITLE: LAYOUT, 21'-8" X 35'-9", LAGOON, LEFT, 8' DEEP, 100 SERIES	
PART NUMBER:	10929
SCALE:	1:192
SHEET:	4 OF 6
SIZE:	A



ENGINEERING DRAWING NUMBER: 00005034	WEIGHT:	UNLESS OTHERWISE SPECIFIED DIMENSIONS ARE IN INCHES TOLERANCES DECIMALS: X ± 0.1 XX ± 0.01 XXX ± 0.005 XXXX ± 0.0005 ANGULAR: X ± 0.5 THIRD ANGLE PROJECTION 	DESIGNED BY:	CREATION DATE:	HYDRA POOLS LAYOUT, 21'-8" X 35'-9", LAGOON, LEFT, 8" DEEP, 100 SERIES		
	lbs		RCOLBOCH	6/10/2013			
	VOLUME:		DETAILED BY:	DETAILED DATE:			
	Inch ³		JBOSSEDET	10/5/2012	PART NUMBER:	SCALE:	SIZE:
	COLOR:		LAST REVISED BY:	LAST REVISED DATE:	10929	1:192	A
	NA		jbosserdet	1/26/2015		SHEET:	
	HEAT TREAT:		MATERIAL:			5 OF 6	
NA							
FINISH:							
TEXTURE:							
NA							

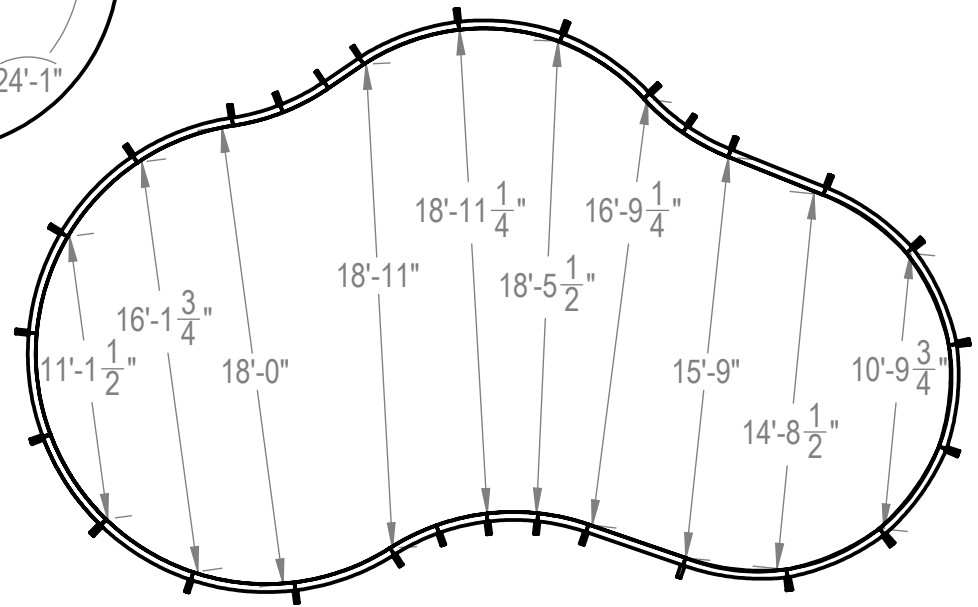
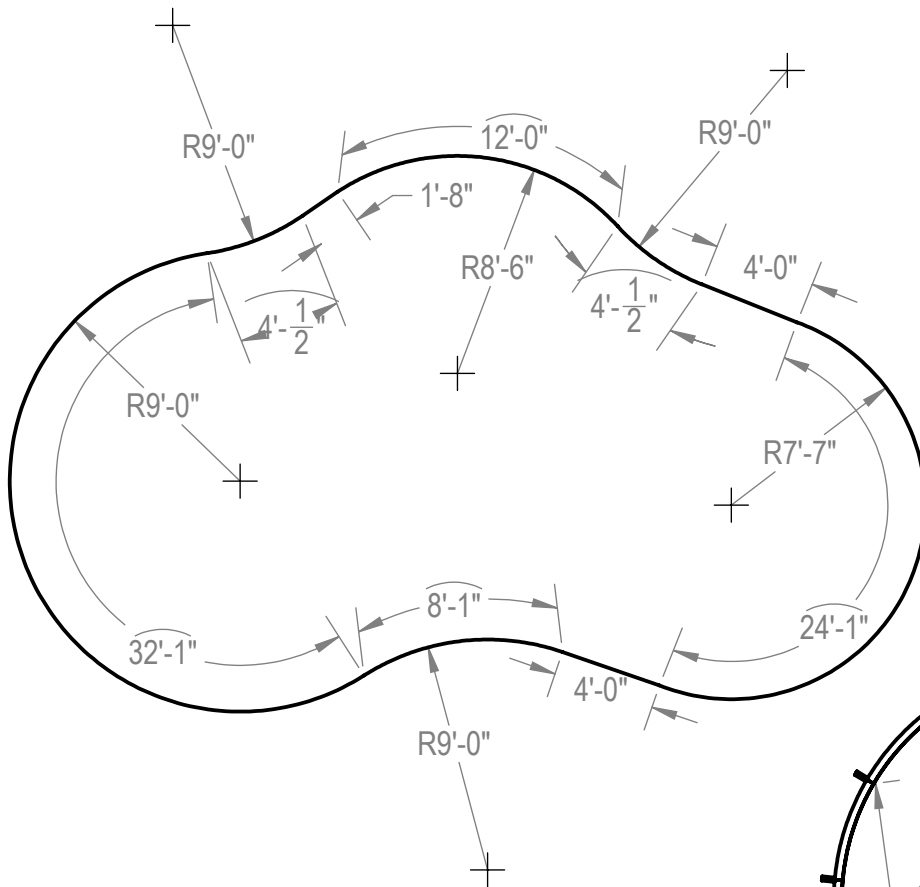

ENGINEERING DRAWING NUMBER: 00005034	WEIGHT:	UNLESS OTHERWISE SPECIFIED DIMENSIONS ARE IN INCHES TOLERANCES DECIMALS: X ± 0.1 XX ± 0.01 XXX ± 0.005 XXXX ± 0.0005 ANGULAR: X ± 0.5 THIRD ANGLE PROJECTION	DESIGNED BY:	CREATION DATE:	HYDRA POOLS
	lbs		RCOLBOCH	6/10/2013	
	VOLUME:		DETAILED BY:	DETAILED DATE:	
	Inch ³		JBOSSERDET	10/5/2012	TITLE: LAYOUT, 21'-8" X 35'-9", LAGOON, LEFT, 8' DEEP, 100 SERIES
	COLOR:		LAST REVISED BY:	LAST REVISED DATE:	
	HEAT TREAT:		jbosserdet	1/26/2015	
NA	MATERIAL:		PART NUMBER:	SCALE:	SIZE:
FINISH:			10929	1:192	A
TEXTURE:				6 OF 6	
NA					