

REVISION HISTORY				
REV.	DESCRIPTION	DATE	ECO	BY
A	2014 POLYMER DIG BOOK	12/23/13	NONE	THARKENRIDER
B	UPDATED TAG DATA TO INCLUDE COPING LENGTHS.	1/23/2015	391702	JBOSSERDET

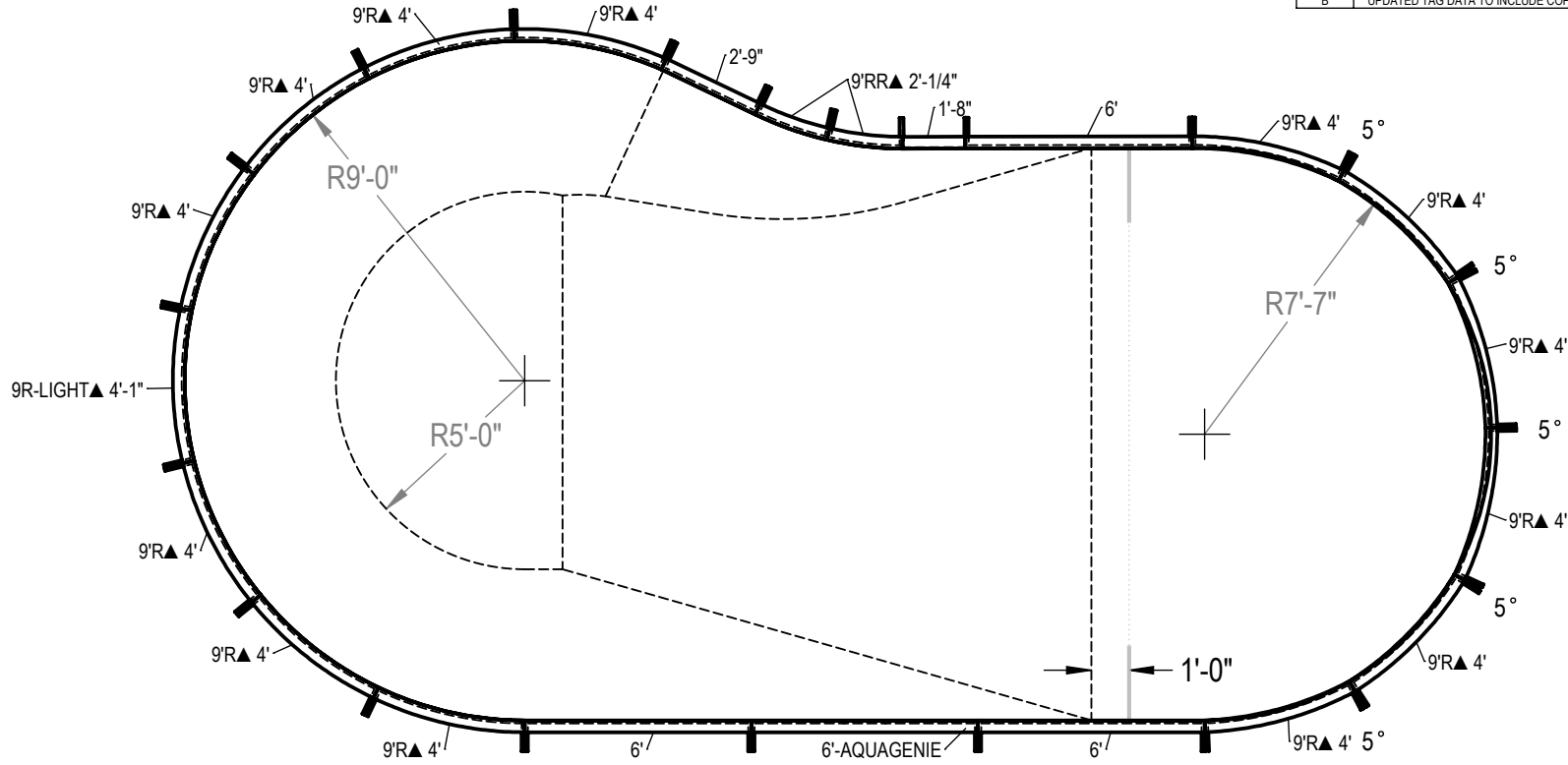

ITEM	FILE NAME	DESCRIPTION	CUSTOMER DRAWING #	VENDOR PART #	QTY.	VENDOR NAME	MATERIAL
1	BRACE	BRACE, 4 TAB, HYDRA - 100 SERIES	HP199	HP199	22	HYDRA POOLS	PS
2	INSERT, 5° WEDGE	INSERT, 5° WEDGE	HP226	HP226	5	HYDRA POOLS, IA	PP Homopolymer
3	PANEL, 1'-8 IN LONG	PANEL, 1'-8" LONG - 100 SERIES	HP116	HP116	1	HYDRA POOLS	PS
4	PANEL, 2'-9 IN LONG	PANEL, 2'-9" LONG - 100 SERIES	HP117	HP117	1	HYDRA POOLS	PS
5	PANEL, 6' LONG	PANEL, 6' LONG - 100 SERIES	HP106	HP106	3	HYDRA POOLS	PS
6	PANEL, 6' LONG WITH AQUA GENIE	PANEL, 6' LONG WITH AQUA GENIE - 100 SERIES	HP106A	HP106A	1	HYDRA POOLS	PS
7	PANEL, 9' RADIUS WITH LIGHT	PANEL, 9' RADIUS WITH LIGHT - 100 SERIES	HP159LL	HP159LL	1	HYDRA POOLS	PS
8	PANEL, 9' RADIUS, 4' LONG	PANEL, 9' RADIUS, 4' LONG - 100 SERIES	HP159	HP159	13	HYDRA POOLS	PS
9	PANEL, 9' REVERSE RADIUS	PANEL, 9' REVERSE RADIUS - 100 SERIES	HP119N	HP119N	2	HYDRA POOLS	PS

**NOTES:**

- THESE ARE FINISHED DIMENSIONS READY FOR THE LINER.
- DIMENSIONS ARE FROM INSIDE POOL PANELS.
- THE IDEAL WATER LEVEL SHOULD BE TO THE MIDDLE OF THE SKIMMER OPENING(S).

**EXCAVATION NOTES:**

- ROUGH EXCAVATION SHOULD BE 2" DEEPER IN EACH INSTANCE.
- SOIL TO HAVE MINIMUM BEARING CAPACITY OF 1500 PSF.
- LOCATE TOP OF POOL AT LEAST 6" ABOVE THE SURROUNDING LAND ELEVATION.
- SEE "OVER DIG DETAIL" FOR EXCAVATION AROUND POOL.
- FILL VOIDS UNDER BASE OF PANELS AND TAMP WELL.
- BACK FILL WITH NON-EXPANSIVE MATERIAL.
- ANSI / APSP / ICC-5 FOR RESIDENTIAL POOLS, 2003-2007 BOCA CODE SECTION 421.

**IMPORTANT NOTES:**

- THIS DOCUMENT IS FOR ILLUSTRATIVE PURPOSES ONLY. THE DEALER OR CONTRACTOR WHO SELLS OR INSTALLS YOUR POOL IS AN INDEPENDENT CONTRACTOR AND IS NOT AN AGENT OF THE MANUFACTURER. THE CONSTRUCTION METHODS ILLUSTRATED HERE ARE SUGGESTIONS AND APPLY ONLY TO NORMAL GROUND CONDITIONS. THERE MAY BE ADDITIONAL PRECAUTIONS AND/OR METHODS OF CONSTRUCTION. PROPER INSTALLATION IS THE RESPONSIBILITY OF THE DEALER/BUILDER/CONTRACTOR.

ENGINEERING DRAWING NUMBER:  
00004956

WEIGHT: lbs	<b>UNLESS OTHERWISE SPECIFIED</b> DIMENSIONS ARE IN INCHES TOLERANCES DECIMALS: X ± 0.1 XX ± 0.01 XXX ± 0.005 XXXX ± 0.0005 ANGULAR: X ± 0.5 THIRD ANGLE PROJECTION
VOLUME: Inch <sup>3</sup>	
COLOR:	
HEAT TREAT:	
FINISH:	
TEXTURE:	

DESIGNED BY: RCOLBOCH	CREATION DATE: 7/16/2013
DETAILED BY: JBOSSERDET	DETAILED DATE: 10/5/2012
LAST REVISED BY: jbosserdet	LAST REVISED DATE: 1/23/2015
MATERIAL:	

<b>HYDRA POOLS</b>	
<b>LAYOUT, 18' X 34'-7", KIDNEY, STRAIGHT WALL, RIGHT, 8' DEEP, 100 SERIES</b>	
PART NUMBER: <b>10728</b>	SCALE: 1:128 SHEET: 1 OF 6 SIZE: <b>A</b>

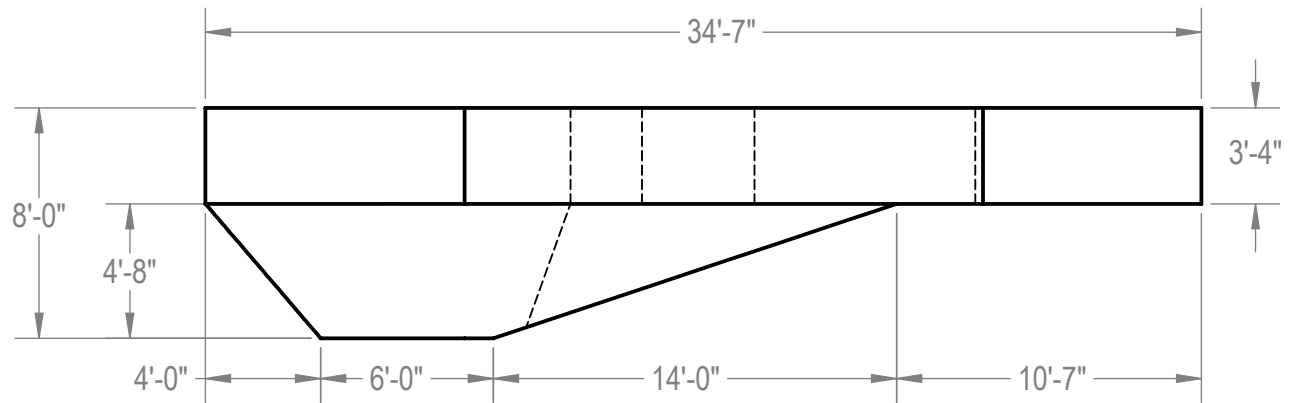
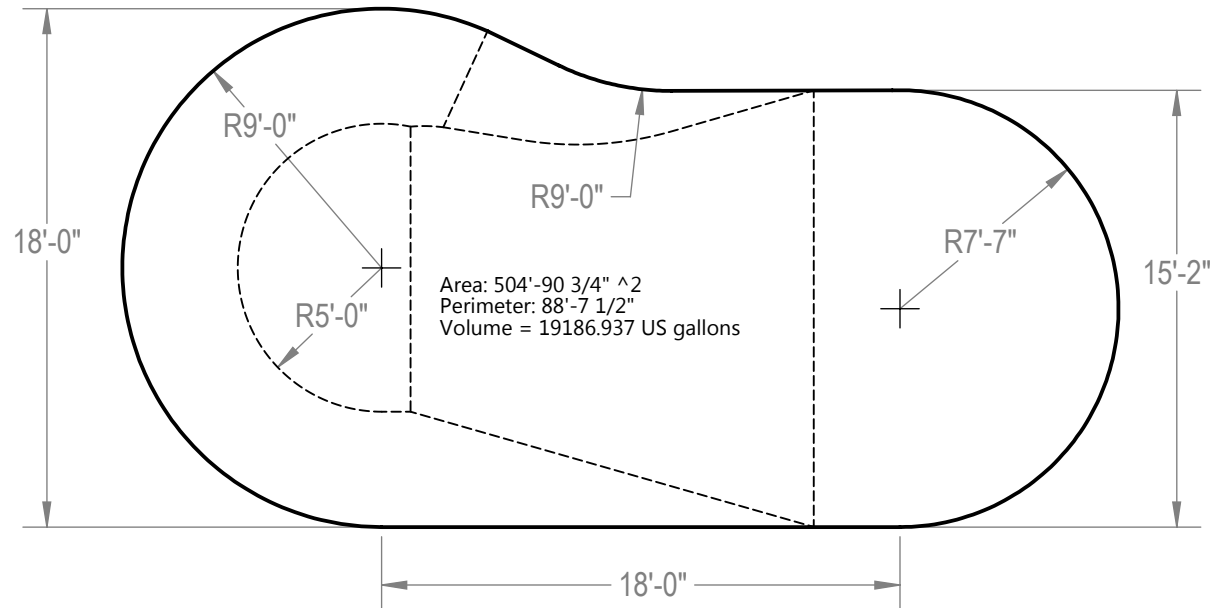
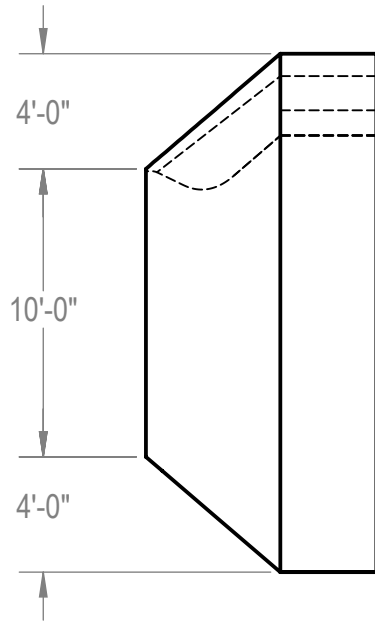

**NOTES:**

1. THESE ARE FINISHED DIMENSIONS READY FOR THE LINER.
2. DIMENSIONS ARE FROM INSIDE POOL PANELS.
3. THE IDEAL WATER LEVEL SHOULD BE TO THE MIDDLE OF THE SKIMMER OPENING(S).

**EXCAVATION NOTES:**

4. ROUGH EXCAVATION SHOULD BE 2" DEEPER IN EACH INSTANCE.
5. SOIL TO HAVE MINIMUM BEARING CAPACITY OF 1500 PSF.
6. LOCATE TOP OF POOL AT LEAST 6" ABOVE THE SURROUNDING LAND ELEVATION.
7. SEE "OVER DIG DETAIL" FOR EXCAVATION AROUND POOL.
8. FILL VOIDS UNDER BASE OF PANELS AND TAMP WELL.
9. BACK FILL WITH NON-EXPANSIVE MATERIAL.
10. ANSI / APSP / ICC-5 FOR RESIDENTIAL POOLS, 2003-2007 BOCA CODE SECTION 421.

**IMPORTANT NOTES:**

11. THIS DOCUMENT IS FOR ILLUSTRATIVE PURPOSES ONLY. THE DEALER OR CONTRACTOR WHO SELLS OR INSTALLS YOUR POOL IS AN INDEPENDENT CONTRACTOR AND IS NOT AN AGENT OF THE MANUFACTURER. THE CONSTRUCTION METHODS ILLUSTRATED HERE ARE SUGGESTIONS AND APPLY ONLY TO NORMAL GROUND CONDITIONS. THERE MAY BE ADDITIONAL PRECAUTIONS AND/OR METHODS OF CONSTRUCTION. PROPER INSTALLATION IS THE RESPONSIBILITY OF THE DEALER/BUILDER/CONTRACTOR.

ENGINEERING DRAWING NUMBER: <b>00004956</b>	<b>WEIGHT:</b> 160122.707 lbs <b>VOLUME:</b> 4432182.517 Inch <sup>3</sup>	<b>UNLESS OTHERWISE SPECIFIED</b> DIMENSIONS ARE IN INCHES TOLERANCES DECIMALS: X ± .1 XX ± .01 XXX ± .001 XXXX ± .0005  ANGULAR: X ± 0.5 THIRD ANGLE PROJECTION	<b>DESIGNED BY:</b> THARKENRIDER	<b>CREATION DATE:</b> 12/23/2013	<b>HYDRA POOLS</b>  <b>LAYOUT, 18' X 34'-7", KIDNEY,          STRAIGHT WALL, RIGHT, 8' DEEP, 100          SERIES</b>
	<b>COLOR:</b> NA <b>HEAT TREAT:</b> NA <b>FINISH:</b> NA <b>TEXTURE:</b> NA		<b>DETAILED BY:</b> JBOSSERDET	<b>DETAILED DATE:</b> 10/5/2012	
	<b>MATERIAL:</b> Water		<b>LAST REVISED BY:</b> jbosserdet	<b>LAST REVISED DATE:</b> 1/23/2015	
	<b>PART NUMBER:</b> <div style="font-size: 2em; font-weight: bold; text-align: center;">10728</div>		<b>SCALE:</b> 1:128 <b>SHEET:</b> 2 OF 6	<b>SIZE:</b> <div style="font-size: 2em; font-weight: bold; text-align: center;">A</div>	

A-S1	27'-7 1/2"
B-S1	14'-9 1/2"
A-S2	34'-2 1/2"
B-S2	25'- 1/4"
A-S3	14'-9 3/4"
B-S3	28'-5 3/4"
A-S4	21'-4 3/4"
B-S4	32'-4 3/4"

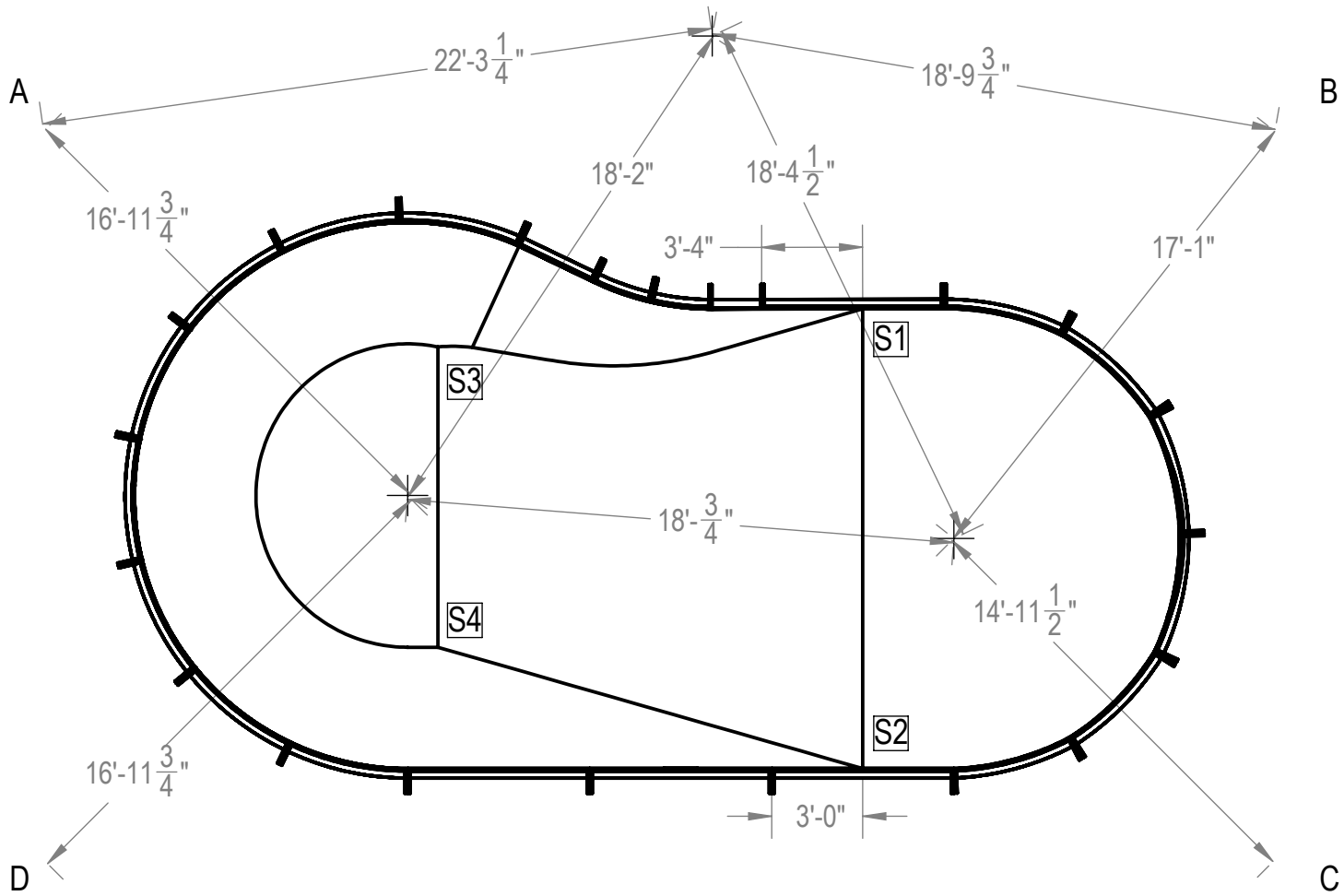

ENGINEERING DRAWING NUMBER: <b>00004956</b>	WEIGHT:	<b>UNLESS OTHERWISE SPECIFIED</b> DIMENSIONS ARE IN INCHES TOLERANCES DECIMALS: X ± 0.1 XX ± 0.01 XXX ± 0.005 XXXX ± 0.0005 ANGULAR: X ± 0.5 THIRD ANGLE PROJECTION	DESIGNED BY:	CREATION DATE:	<b>HYDRA POOLS</b>  <b>LAYOUT, 18' X 34'-7", KIDNEY,          STRAIGHT WALL, RIGHT, 8' DEEP, 100          SERIES</b>
	lbs		RCOLBOCH	7/16/2013	
	VOLUME:		DETAILED BY:	DETAILED DATE:	
	Inch <sup>3</sup>		JBOSSERDET	10/5/2012	
	COLOR:		LAST REVISED BY:	LAST REVISED DATE:	
NA	jbosserdet	1/23/2015	TITLE:		
HEAT TREAT:	MATERIAL:		PART NUMBER:	SCALE:	SIZE:
NA			<b>10728</b>	1:128	<b>A</b>
FINISH:				SHEET:	
NA				3 OF 6	
TEXTURE:					
NA					

	A	B	C	D
1	10'-7 3/4"	38'-9"	39'-10 1/2"	14'-2 1/2"
2	8'-1 3/4"	36'-4"	39'-9 1/4"	18'-1 1/2"
3	8'-10"	32'-11 1/4"	38'-4"	21'-6"
4	12'-1 1/4"	29'- 1/4"	35'-8 1/4"	24'- 1/2"
5	16'-1 1/2"	25'-2 1/2"	32'-1"	25'-7"
6	18'-9 3/4"	22'-11 3/4"	29'-5"	26'-3 1/2"
7	20'-9 1/4"	21'-4"	27'-7 1/4"	27'-2"
8	22'-10"	19'-5 1/4"	25'-11 1/4"	28'-6 3/4"
9	24'-4 1/2"	17'-10 3/4"	24'-9 3/4"	29'-10"
10	30'-3 1/2"	12'-4"	21'-2"	34'-10"
11	34'-2 1/2"	9'-8 3/4"	18'-8"	37'-8 3/4"
12	37'-7 3/4"	10'-3 1/2"	15'-2"	39'-3"
13	39'-8 1/2"	13'-7 1/2"	11'-2 1/4"	38'-11 1/4"
14	40'-5"	17'-7"	7'-11 1/4"	37'-3"
15	39'-3 1/4"	21'-1"	7'-10 1/2"	34'- 3/4"
16	36'-7 1/2"	23'-6 1/4"	11'-0"	30'-1 3/4"
17	31'-10 3/4"	26'-9"	16'-10 1/4"	24'-2 1/4"
18	27'-8"	30'-10"	22'-9 1/2"	18'-3"
19	24'-2 1/4"	35'-5 3/4"	28'-9"	12'-4 1/2"
20	21'-8 1/2"	38'-2 1/4"	32'-8 1/4"	9'-0"
21	18'-4 1/2"	39'-8 3/4"	36'-1 1/2"	8'- 3/4"
22	14'-5 3/4"	39'-11"	38'-7 1/2"	10'-4 3/4"

A-B	40'-7"
B-C	24'-0"
A-C	47'-1 3/4"

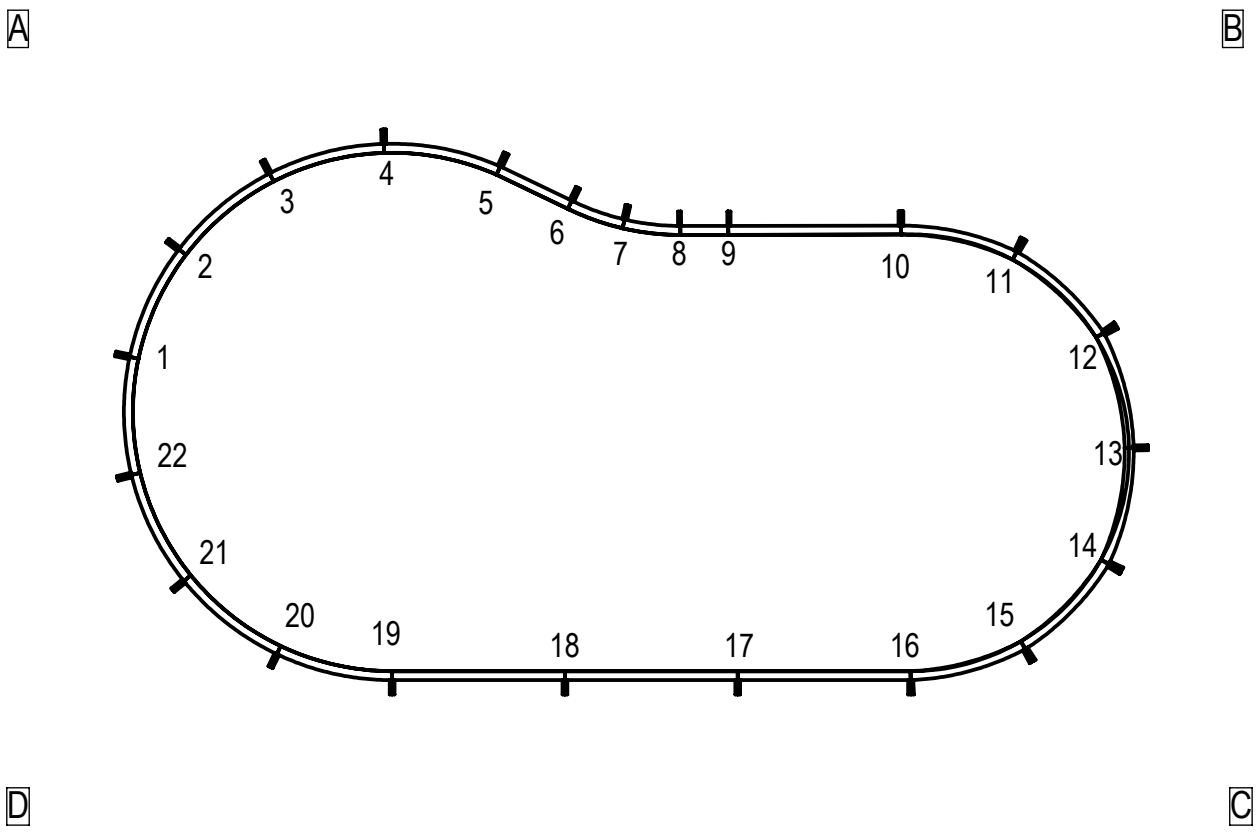

ENGINEERING DRAWING NUMBER: <b>00004956</b>	WEIGHT:	<b>UNLESS OTHERWISE SPECIFIED</b> DIMENSIONS ARE IN INCHES TOLERANCES DECIMALS: X ± 0.1 XX ± 0.01 XXX ± 0.005 XXXX ± 0.0005 ANGULAR: X ± 0.5 THIRD ANGLE PROJECTION	DESIGNED BY:	CREATION DATE:	<b>HYDRA POOLS</b>  <b>LAYOUT, 18' X 34'-7", KIDNEY,          STRAIGHT WALL, RIGHT, 8' DEEP, 100          SERIES</b>
	lbs		RCOLBOCH	7/16/2013	
	VOLUME:		DETAILED BY:	DETAILED DATE:	
	Inch <sup>3</sup>		JBOSSERDET	10/5/2012	
	COLOR:		LAST REVISED BY:	LAST REVISED DATE:	
NA	jbosserdet	1/23/2015	TITLE:		
HEAT TREAT:	MATERIAL:		PART NUMBER:	SCALE:	SIZE:
NA				1:128	1:128
FINISH:				4 OF 6	<b>A</b>
TEXTURE:					
NA					

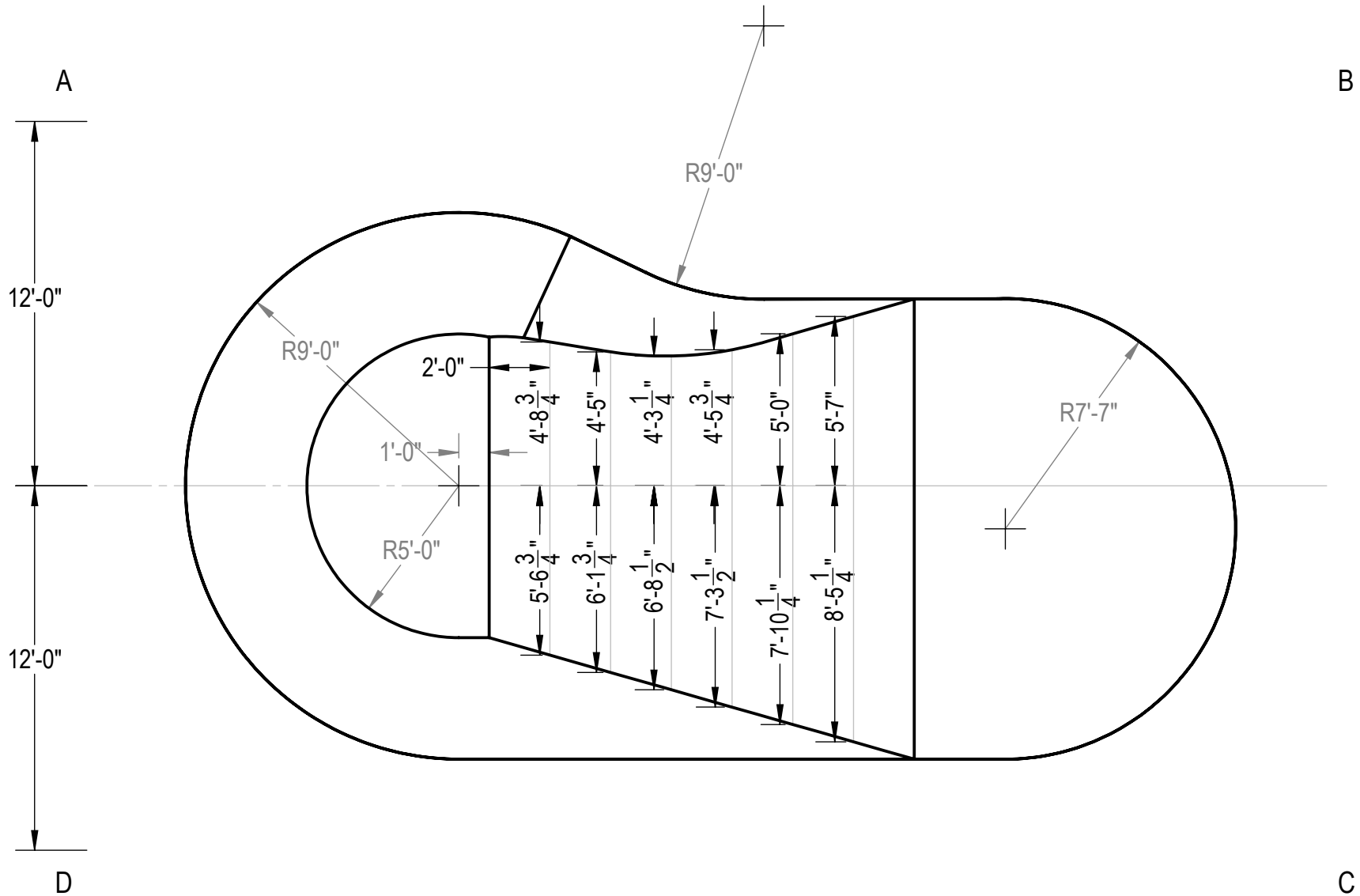

ENGINEERING DRAWING NUMBER: <b>00004956</b>	WEIGHT: 160122.707 lbs	<b>UNLESS OTHERWISE SPECIFIED</b> DIMENSIONS ARE IN INCHES TOLERANCES DECIMALS: X ± 0.1 XX ± 0.01 XXX ± 0.005 XXXX ± 0.0005 ANGULAR: X ± 0.5 THIRD ANGLE PROJECTION 	DESIGNED BY: THARKENRIDER	CREATION DATE: 12/23/2013	<b>HYDRA POOLS</b>  <b>LAYOUT, 18' X 34'-7", KIDNEY,          STRAIGHT WALL, RIGHT, 8' DEEP, 100          SERIES</b>
	VOLUME: 4432182.517 Inch <sup>3</sup>		DETAILED BY: JBOSSERDET	DETAILED DATE: 10/5/2012	
	COLOR: NA		LAST REVISED BY: jbosserdet	LAST REVISED DATE: 1/23/2015	
	HEAT TREAT: NA		MATERIAL: Water	PART NUMBER: <b>10728</b>	
	FINISH: NA			SCALE: 1:128	
	TEXTURE: NA			SHEET: 5 OF 6	
					<b>A</b>

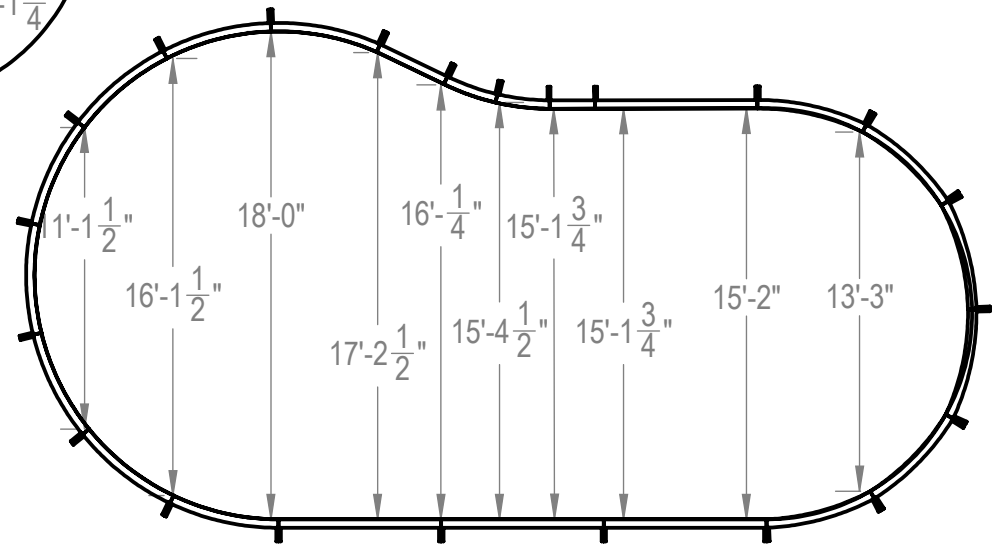
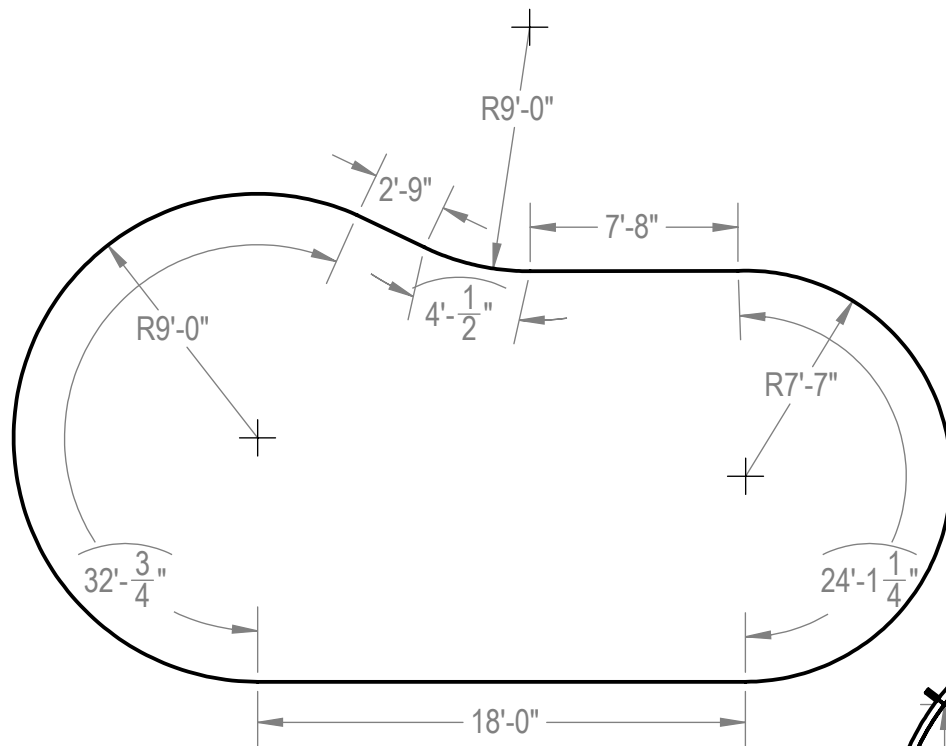

ENGINEERING DRAWING NUMBER: <b>00004956</b>	WEIGHT:	<b>UNLESS OTHERWISE SPECIFIED</b> DIMENSIONS ARE IN INCHES TOLERANCES DECIMALS: X ± 0.1 XX ± 0.01 XXX ± 0.005 XXXX ± 0.0005 ANGULAR: X ± 0.5 THIRD ANGLE PROJECTION	DESIGNED BY:	CREATION DATE:	<b>HYDRA POOLS</b>  <b>LAYOUT, 18' X 34'-7", KIDNEY,          STRAIGHT WALL, RIGHT, 8' DEEP, 100          SERIES</b>
	lbs		RCOLBOCH	7/16/2013	
	VOLUME:		DETAILED BY:	DETAILED DATE:	
	Inch <sup>3</sup>		JBOSSERDET	10/5/2012	
	COLOR:		LAST REVISED BY:	LAST REVISED DATE:	
	NA		jbosserdet	1/23/2015	
HEAT TREAT:	MATERIAL:	PART NUMBER:	SCALE:	SIZE:	
NA		<b>10728</b>	1:128	<b>A</b>	
FINISH:			SHEET:		
NA			6 OF 6		
TEXTURE:					
NA					