

REVISION HISTORY				
REV.	DESCRIPTION	DATE	ECO	BY
A	RELEASED FOR PRODUCTION	12/12/2013	NONE	RCOLBOCH
B	UPDATED TAG DATA TO INCLUDE COPING LENGTHS.	1/19/2015	391702	JBOSSERDET

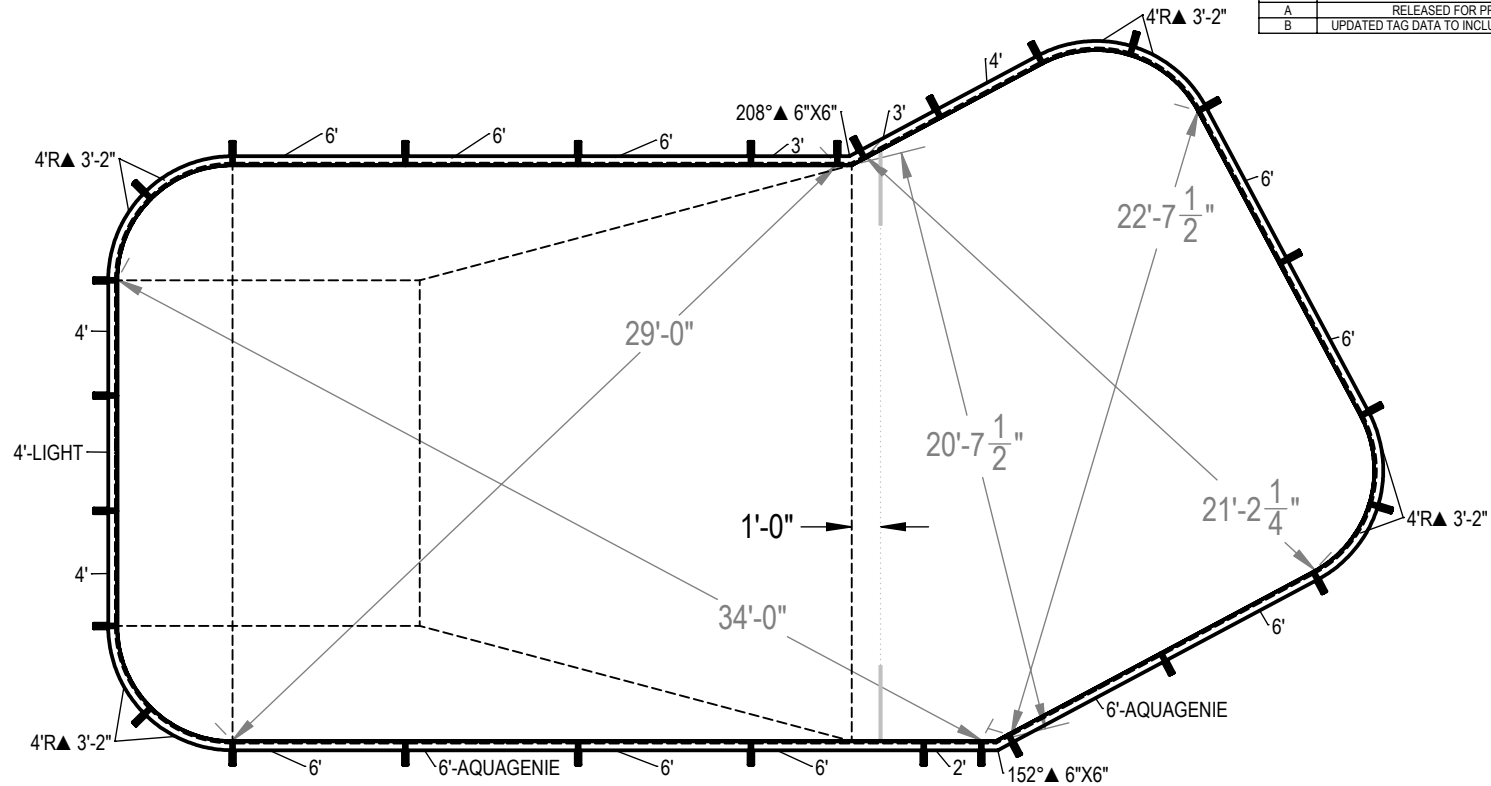

ITEM	FILE NAME	DESCRIPTION	CUSTOMER DRAWING #	VENDOR PART #	QTY.	VENDOR NAME	MATERIAL
1	BRACE	BRACE, 4 TAB, HYDRA - 100 SERIES	HP199	HP199	27	HYDRA POOLS	PS
2	PANEL, 2' LONG	PANEL, 2' LONG - 100 SERIES	HP102	HP102	1	HYDRA POOLS	PS
3	PANEL, 3' LONG	PANEL, 3' LONG - 100 SERIES	HP103	HP103	2	HYDRA POOLS	PS
4	PANEL, 4' LONG	PANEL, 4' LONG - 100 SERIES	HP104	HP104	3	HYDRA POOLS	PS
5	PANEL, 4' LONG WITH LIGHT	PANEL, 4' LONG WITH LIGHT - 100 SERIES	HP104L	HP104L	1	HYDRA POOLS	PS
6	PANEL, 4' RADIUS	PANEL, 4' RADIUS - 100 SERIES	HP154	HP154	8	HYDRA POOLS	PS
7	PANEL, 6' LONG	PANEL, 6' LONG - 100 SERIES	HP106	HP106	9	HYDRA POOLS	PS
8	PANEL, 6' LONG WITH AQUA GENIE	PANEL, 6' LONG WITH AQUA GENIE - 100 SERIES	HP106A	HP106A	2	HYDRA POOLS	PS
9	PANEL, L, 152° X 6 IN X 6 IN	PANEL, L, 152° X 6" X 6" - 100 SERIES	HP121	HP121	1	HYDRA POOLS	PS
10	PANEL, L, 208° X 6 IN X 6 IN	PANEL, L, 208° X 6" X 6" - 100 SERIES	HP120	HP120	1	HYDRA POOLS	PS

NOTES:

- THESE ARE FINISHED DIMENSIONS READY FOR THE LINER.
- DIMENSIONS ARE FROM INSIDE POOL PANELS.
- THE IDEAL WATER LEVER SHOULD BE TO THE MIDDLE OF THE SKIMMER OPENING(S).

EXCAVATION NOTES:

- ROUGH EXCAVATION SHOULD BE 2" DEEPER IN EACH INSTANCE.
- SOIL TO HAVE MINIMUM BEARING CAPACITY OF 2000 PSF.
- LOCATE TOP OF POOL AT LEAST 6" ABOVE THE SURROUNDING LAND ELEVATION.
- SEE "OVER DIG DETAIL" FOR EXCAVATION AROUND POOL.
- FILL VOIDS UNDER BASE OF PANELS AND TAMP WELL.
- BACK FILL WITH NON-EXPANSIVE MATERIAL.

IMPORTANT NOTES:

THIS DOCUMENT IS FOR ILLUSTRATIVE PURPOSES ONLY. THE DEALER OR CONTRACTOR WHO SELLS OR INSTALLS YOUR POOL IS AN INDEPENDENT CONTRACTOR AND IS NOT AN AGENT OF THE MANUFACTURER. THE CONSTRUCTION METHODS ILLUSTRATED HERE ARE SUGGESTIONS AND APPLY ONLY TO NORMAL GROUND CONDITIONS. THERE MAY BE ADDITIONAL PRECAUTIONS AND/OR METHODS OF CONSTRUCTION. PROPER INSTALLATION IS THE RESPONSIBILITY OF THE DEALER/BUILDER/CONTRACTOR.

ENGINEERING DRAWING NUMBER: 00004805	UNLESS OTHERWISE SPECIFIED DIMENSIONS ARE IN INCHES TOLERANCES DECIMALS: X ± .1 XX ± .01 XXX ± .001 XXXX ± .0005 ANGULAR: X ± 0.5 THIRD ANGLE PROJECTION	DESIGNED BY: RCOLBOCH DETAILED BY: JBOSSERDET LAST REVISED BY: jbosserdet MATERIAL:	CREATION DATE: 8/12/2013 DETAILED DATE: 10/5/2012 LAST REVISED DATE: 1/19/2015	HYDRA POOLS TITLE: LAYOUT, 20' X 43'-7", LAZY L, RIGHT, 4' RADIUS, 8" DEEP, 100 SERIES
	PART NUMBER:			10461
	SCALE: 1:192 SHEET: 1 OF 2			A
	C:\PDM\working\00004805			

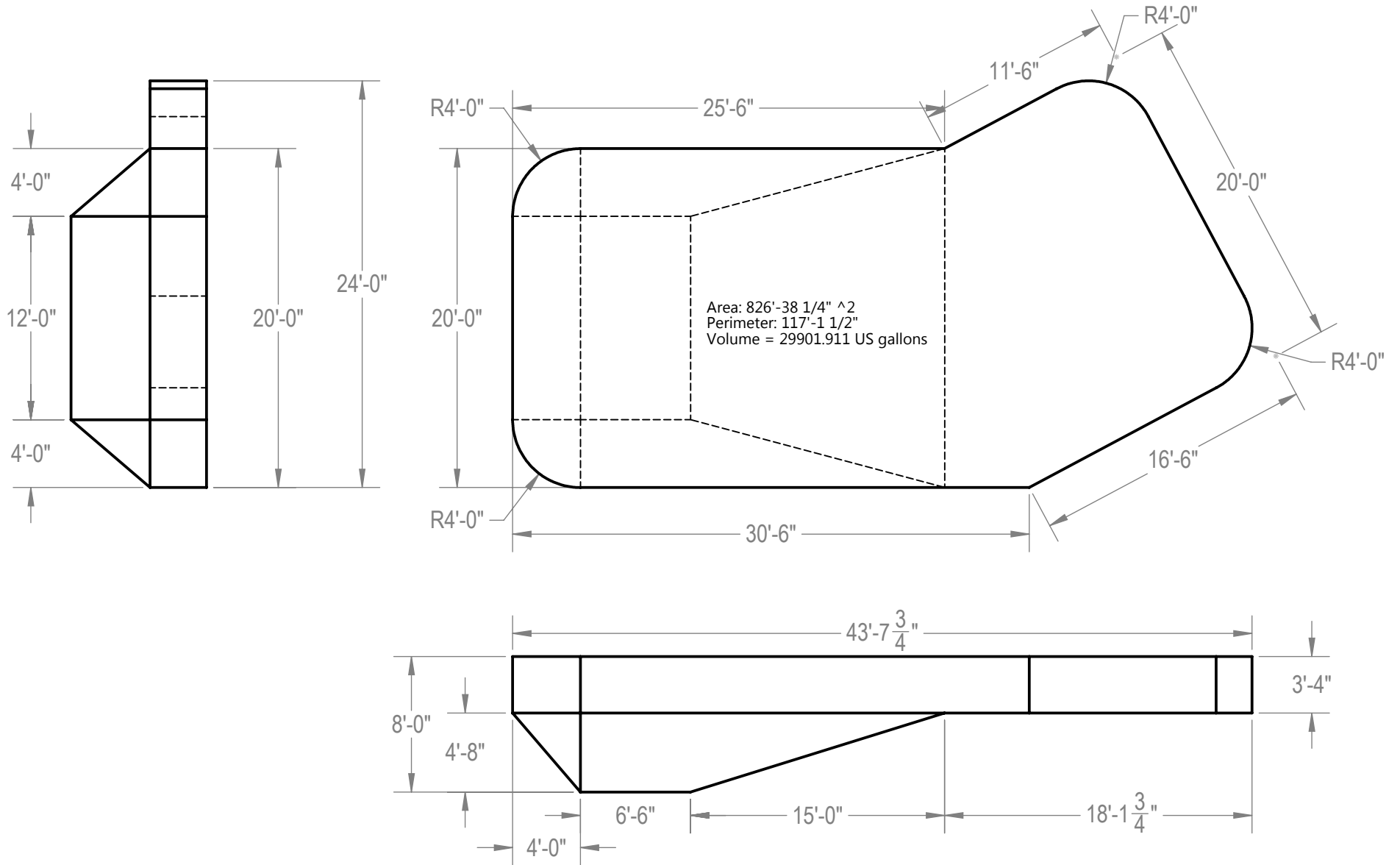

NOTES:

1. THESE ARE FINISHED DIMENSIONS READY FOR THE LINER.
2. DIMENSIONS ARE FROM INSIDE POOL PANELS.
3. THE IDEAL WATER LEVER SHOULD BE TO THE MIDDLE OF THE SKIMMER OPENING(S).

EXCAVATION NOTES:

4. ROUGH EXCAVATION SHOULD BE 2" DEEPER IN EACH INSTANCE.
5. SOIL TO HAVE MINIMUM BEARING CAPACITY OF 2000 PSF.
6. LOCATE TOP OF POOL AT LEAST 6" ABOVE THE SURROUNDING LAND ELEVATION.
7. SEE "OVER DIG DETAIL" FOR EXCAVATION AROUND POOL.
8. FILL VOIDS UNDER BASE OF PANELS AND TAMP WELL.
9. BACK FILL WITH NON-EXPANSIVE MATERIAL.

IMPORTANT NOTES:

THIS DOCUMENT IS FOR ILLUSTRATIVE PURPOSES ONLY. THE DEALER OR CONTRACTOR WHO SELLS OR INSTALLS YOUR POOL IS AN INDEPENDENT CONTRACTOR AND IS NOT AN AGENT OF THE MANUFACTURER. THE CONSTRUCTION METHODS ILLUSTRATED HERE ARE SUGGESTIONS AND APPLY ONLY TO NORMAL GROUND CONDITIONS. THERE MAY BE ADDITIONAL PRECAUTIONS AND/OR METHODS OF CONSTRUCTION. PROPER INSTALLATION IS THE RESPONSIBILITY OF THE DEALER/BUILDER/CONTRACTOR.

ENGINEERING DRAWING NUMBER: 00004805	WEIGHT:	UNLESS OTHERWISE SPECIFIED DIMENSIONS ARE IN INCHES TOLERANCES DECIMALS: X ± .1 XX ± .01 XXX ± .001 XXXX ± .0005 ANGULAR: X ± 0.5 THIRD ANGLE PROJECTION	DESIGNED BY:	CREATION DATE:	HYDRA POOLS LAYOUT, 20' X 43'-7", LAZY L, RIGHT, 4' RADIUS, 8' DEEP, 100 SERIES
	lbs		RCOLBOCH	12/11/2013	
	VOLUME:		Detailed BY:	DETAILED DATE:	
	Inch ³		JBOSSERDET	10/5/2012	
	COLOR:		LAST REVISED BY:	LAST REVISED DATE:	
NA	jbosserdet	1/19/2015	PART NUMBER:	SCALE:	SIZE:
HEAT TREAT:	MATERIAL:		10461	1:128	A
NA				2 OF 2	
FINISH:					
NA					
TEXTURE:					
NA					