

REVISION HISTORY				
REV.	DESCRIPTION	DATE	ECO	BY
A	RELEASED FOR PRODUCTION	12/6/2013	NONE	RCOLBOCH
B	UPDATED TAG DATA TO INCLUDE COPING LENGTHS.	1/12/2015	391702	JBOSSEDET

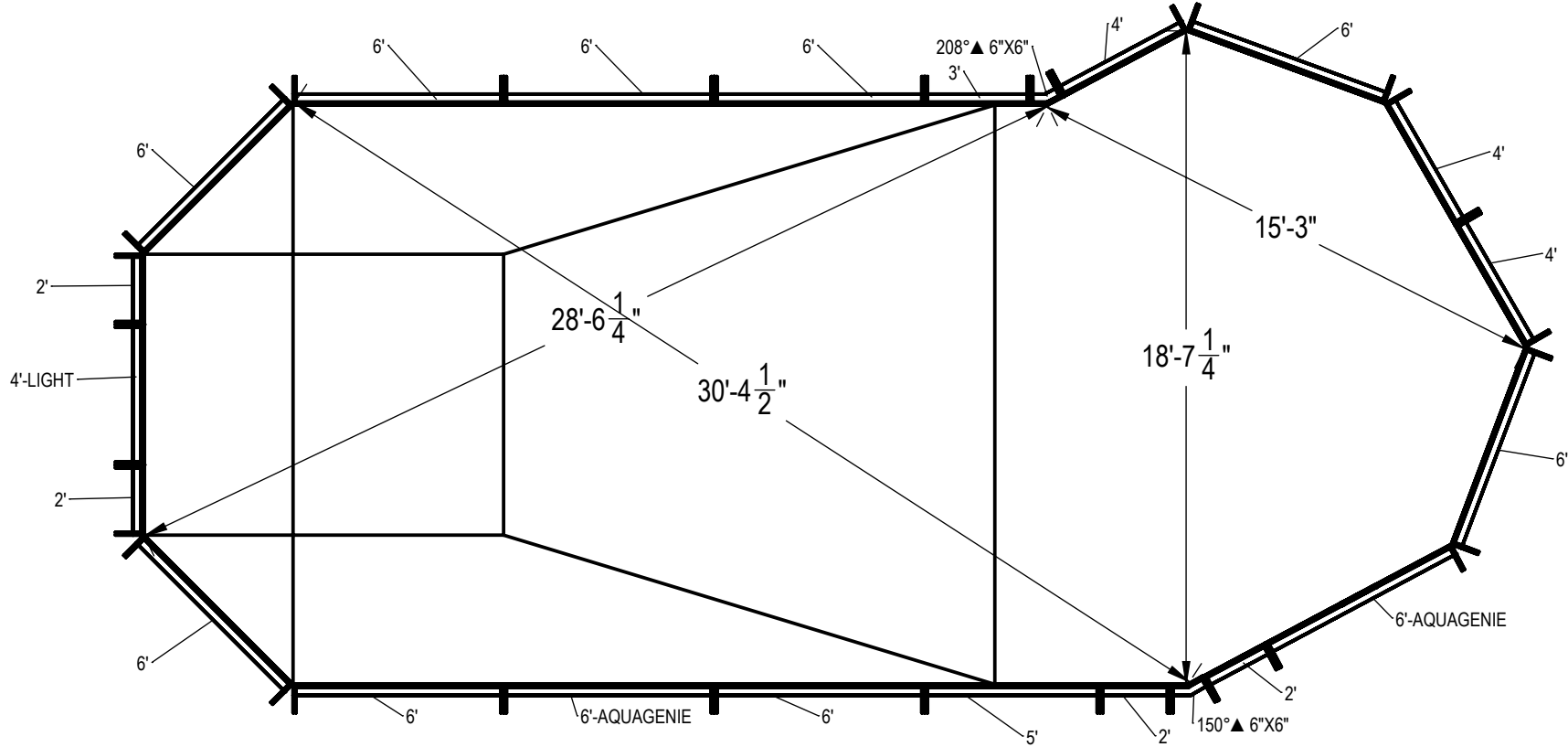

ITEM	FILE NAME	DESCRIPTION	CUSTOMER DRAWING #	VENDOR PART #	QTY.	VENDOR NAME	MATERIAL
1	BRACE	BRACE, 4 TAB, HYDRA - 100 SERIES	HP199	HP199	22	HYDRA POOLS	PS
2	PANEL, 2' LONG	PANEL, 2' LONG - 100 SERIES	HP102	HP102	4	HYDRA POOLS	PS
3	PANEL, 3' LONG	PANEL, 3' LONG - 100 SERIES	HP103	HP103	1	HYDRA POOLS	PS
4	PANEL, 4' LONG	PANEL, 4' LONG - 100 SERIES	HP104	HP104	3	HYDRA POOLS	PS
5	PANEL, 4' LONG WITH LIGHT	PANEL, 4' LONG WITH LIGHT - 100 SERIES	HP104L	HP104L	1	HYDRA POOLS	PS
6	PANEL, 5' LONG	PANEL, 5' LONG - 100 SERIES	HP105	HP105	1	HYDRA POOLS	PS
7	PANEL, 6' LONG	PANEL, 6' LONG - 100 SERIES	HP106	HP106	9	HYDRA POOLS	PS
8	PANEL, 6' LONG WITH AQUA GENIE	PANEL, 6' LONG WITH AQUA GENIE - 100 SERIES	HP106A	HP106A	2	HYDRA POOLS	PS
9	PANEL, L, 150° X 6 IN X 6 IN	PANEL, L, 150° X 6" X 6" - 100 SERIES	HP121	HP121	1	HYDRA POOLS	PS
10	PANEL, L, 208° X 6 IN X 6 IN	PANEL, L, 208° X 6" X 6" - 100 SERIES	HP120	HP120	1	HYDRA POOLS	PS
11	BRACE, STEEL CORNER, 45° HYDRA	WEDGE, POLYMER CORNER, 45° HYDRA	HP213	HP213	8	HYDRA POOLS	G-235, 14 GA, CS-B

**NOTES:**

- THESE ARE FINISHED DIMENSIONS READY FOR THE LINER.
- DIMENSIONS ARE FROM INSIDE POOL PANELS.
- THE IDEAL WATER LEVER SHOULD BE TO THE MIDDLE OF THE SKIMMER OPENING(S).

**EXCAVATION NOTES:**

- ROUGH EXCAVATION SHOULD BE 2" DEEPER IN EACH INSTANCE.
- SOIL TO HAVE MINIMUM BEARING CAPACITY OF 2000 PSF.
- LOCATE TOP OF POOL AT LEAST 6" ABOVE THE SURROUNDING LAND ELEVATION.
- SEE "OVER DIG DETAIL" FOR EXCAVATION AROUND POOL.
- FILL VOIDS UNDER BASE OF PANELS AND TAMP WELL.
- BACK FILL WITH NON-EXPANSIVE MATERIAL.

**IMPORTANT NOTES:**

THIS DOCUMENT IS FOR ILLUSTRATIVE PURPOSES ONLY. THE DEALER OR CONTRACTOR WHO SELLS OR INSTALLS YOUR POOL IS AN INDEPENDENT CONTRACTOR AND IS NOT AN AGENT OF THE MANUFACTURER. THE CONSTRUCTION METHODS ILLUSTRATED HERE ARE SUGGESTIONS AND APPLY ONLY TO NORMAL GROUND CONDITIONS. THERE MAY BE ADDITIONAL PRECAUTIONS AND/OR METHODS OF CONSTRUCTION. PROPER INSTALLATION IS THE RESPONSIBILITY OF THE DEALER/BUILDER/CONTRACTOR.

ENGINEERING DRAWING NUMBER: <b>00004725</b>	<b>WEIGHT:</b>	<b>UNLESS OTHERWISE SPECIFIED</b> DIMENSIONS ARE IN INCHES TOLERANCES DECIMALS: X ± .1 XX ± .01 XXX ± .001 XXXX ± .0005  ANGULAR: X ± 0.5 THIRD ANGLE PROJECTION	DESIGNED BY: <b>RCOLBOCH</b>	CREATION DATE: <b>11/22/2013</b>	<b>HYDRA POOLS</b>  <b>LAYOUT, 16'6" X 39' GRECIAN LAZY L RIGHT, 100 SERIES</b>
	<b>VOLUME:</b> Inch <sup>3</sup>		DETAILED BY: <b>JBOSSEDET</b>	DETAILED DATE: <b>10/5/2012</b>	
	<b>COLOR:</b> NA		LAST REVISED BY: <b>jbosserdet</b>	LAST REVISED DATE: <b>1/12/2015</b>	
	<b>HEAT TREAT:</b> NA		MATERIAL:	TITLE:	
<b>FINISH:</b> NA					PART NUMBER: <b>10411</b>
<b>TEXTURE:</b> NA					SCALE: 1:192 SHEET: 1 OF 2
					SIZE: <b>A</b>

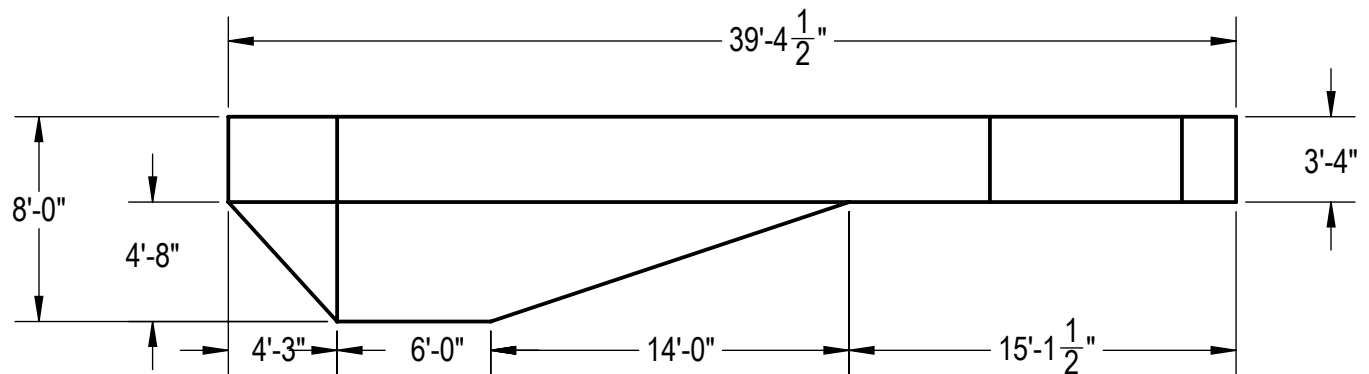
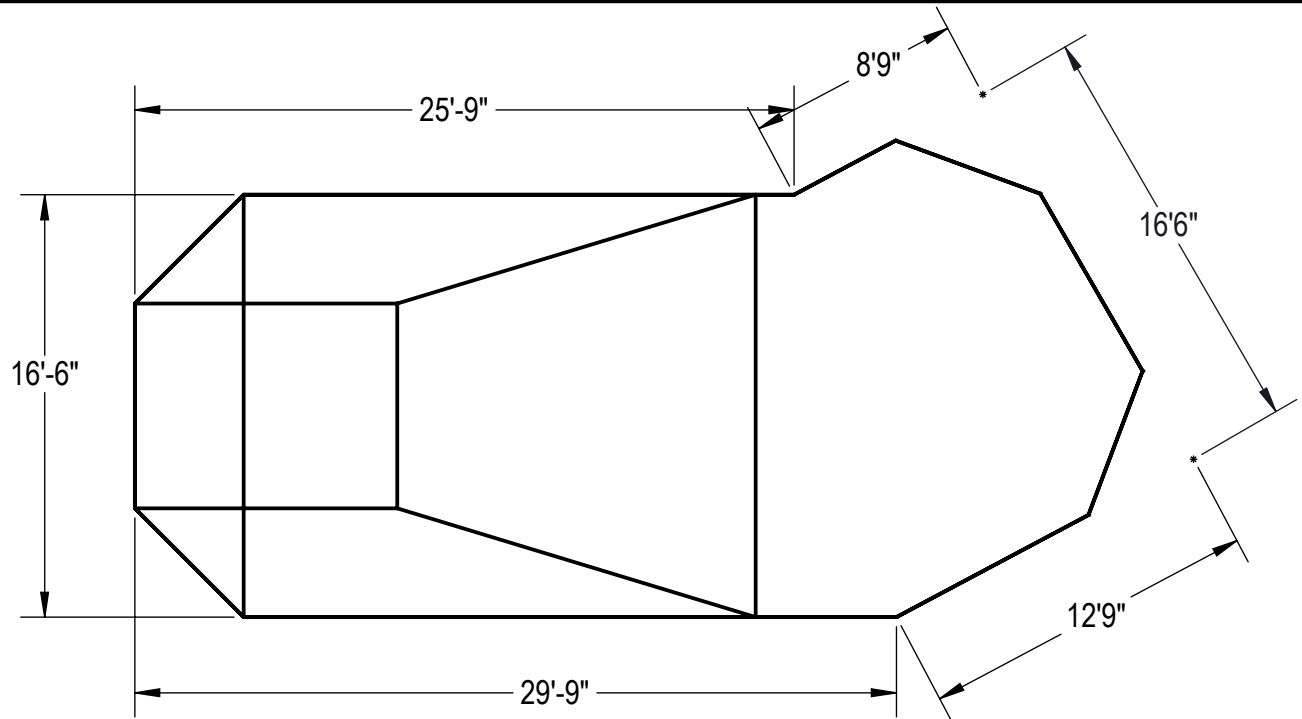
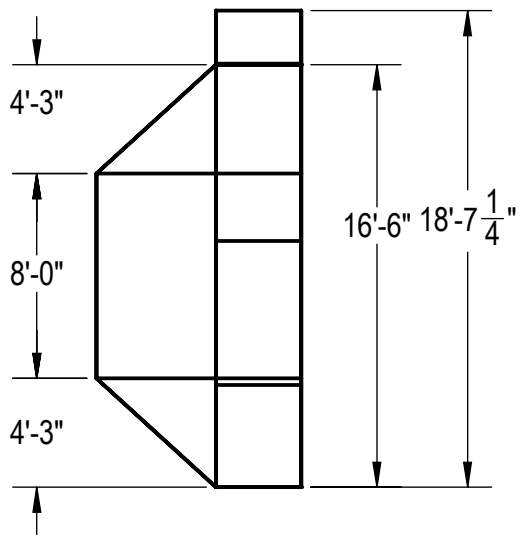

**NOTES:**

1. THESE ARE FINISHED DIMENSIONS READY FOR THE LINER.
2. DIMENSIONS ARE FROM INSIDE POOL PANELS.
3. THE IDEAL WATER LEVER SHOULD BE TO THE MIDDLE OF THE SKIMMER OPENING(S).

**EXCAVATION NOTES:**

4. ROUGH EXCAVATION SHOULD BE 2" DEEPER IN EACH INSTANCE.
5. SOIL TO HAVE MINIMUM BEARING CAPACITY OF 2000 PSF.
6. LOCATE TOP OF POOL AT LEAST 6" ABOVE THE SURROUNDING LAND ELEVATION.
7. SEE "OVER DIG DETAIL" FOR EXCAVATION AROUND POOL.
8. FILL VOIDS UNDER BASE OF PANELS AND TAMP WELL.
9. BACK FILL WITH NON-EXPANSIVE MATERIAL.

**IMPORTANT NOTES:**

THIS DOCUMENT IS FOR ILLUSTRATIVE PURPOSES ONLY. THE DEALER OR CONTRACTOR WHO SELLS OR INSTALLS YOUR POOL IS AN INDEPENDENT CONTRACTOR AND IS NOT AN AGENT OF THE MANUFACTURER. THE CONSTRUCTION METHODS ILLUSTRATED HERE ARE SUGGESTIONS AND APPLY ONLY TO NORMAL GROUND CONDITIONS. THERE MAY BE ADDITIONAL PRECAUTIONS AND/OR METHODS OF CONSTRUCTION. PROPER INSTALLATION IS THE RESPONSIBILITY OF THE DEALER/BUILDER/CONTRACTOR.

ENGINEERING DRAWING NUMBER: <b>00004725</b>	WEIGHT:	<b>UNLESS OTHERWISE SPECIFIED</b> DIMENSIONS ARE IN INCHES TOLERANCES DECIMALS: X ± 0.1 XX ± 0.01 XXX ± 0.005 XXXX ± 0.0005 ANGULAR: X ± 0.5 THIRD ANGLE PROJECTION	DESIGNED BY:	CREATION DATE:	<b>SAMSON STEEL</b>	
	lbs		RCOLBOCH	12/6/2013		
	VOLUME:			DETAILED BY:	DETAILED DATE:	TITLE: <b>LAYOUT, 16'6" X 39' GRECIAN LAZY L          RIGHT, 100 SERIES</b>
	Inch <sup>3</sup>			JBOSSERDET	10/5/2012	
COLOR:		LAST REVISED BY:	LAST REVISED DATE:	PART NUMBER: <b>10411</b>		
NA		jbossdet	1/12/2015			
HEAT TREAT:		MATERIAL:		SCALE:	SIZE:	
NA				1:128	A	
FINISH:				SHEET:		
NA				2 OF 2		
TEXTURE:						
NA						