

REVISION HISTORY				
REV.	DESCRIPTION	DATE	ECO	BY
A	RELEASED FOR PRODUCTION	11/19/2013	NONE	RCOLBOCH
B	ADDED AQUA GENIE	05/06/14	NONE	RCOLBOCH
C	UPDATED TAG DATA TO INCLUDE COPING LENGTHS.	1/9/2015	391702	JBOSSERDET

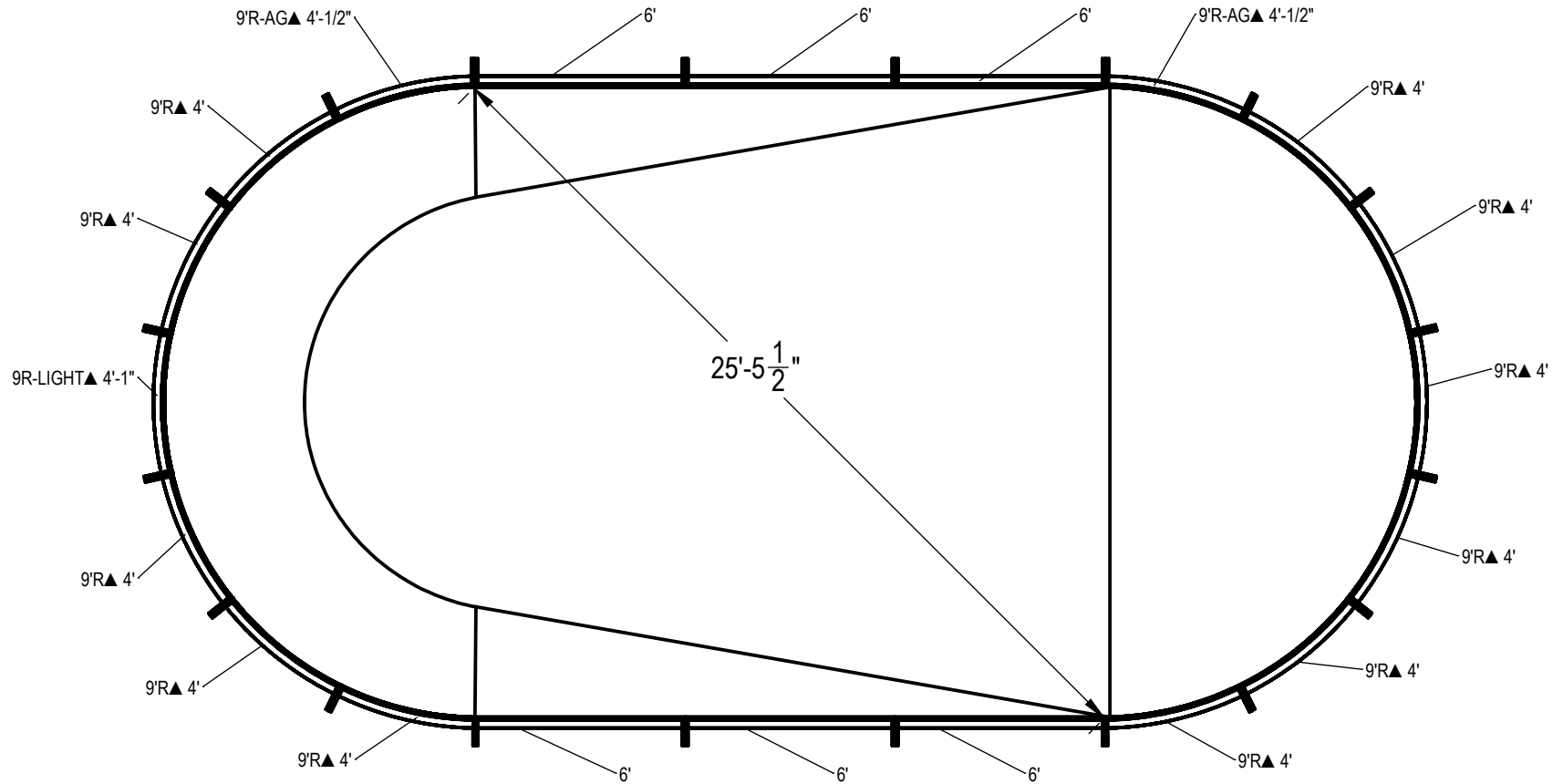

NOTES:

1. THESE ARE FINISHED DIMENSIONS READY FOR THE LINER.
2. DIMENSIONS ARE FROM INSIDE POOL PANELS.
3. THE IDEAL WATER LEVER SHOULD BE TO THE MIDDLE OF THE SKIMMER OPENING(S).

EXCAVATION NOTES:

4. ROUGH EXCAVATION SHOULD BE 2" DEEPER IN EACH INSTANCE.
5. SOIL TO HAVE MINIMUM BEARING CAPACITY OF 1500 PSF.
6. LOCATE TOP OF POOL AT LEAST 6" ABOVE THE SURROUNDING LAND ELEVATION.
7. SEE "OVER DIG DETAIL" FOR EXCAVATION AROUND POOL.
8. FILL VOIDS UNDER BASE OF PANELS AND TAMP WELL.
9. BACK FILL WITH NON-EXPANSIVE MATERIAL.
10. ANSI / APSP / ICC-5 FOR RESIDENTIAL POOLS, 2003-2007 BOCA CODE SECTION 421.

IMPORTANT NOTES:

11. THIS DOCUMENT IS FOR ILLUSTRATIVE PURPOSES ONLY. THE DEALER OR CONTRACTOR WHO SELLS OR INSTALLS YOUR POOL IS AN INDEPENDENT CONTRACTOR AND IS NOT AN AGENT OF THE MANUFACTURER. THE CONSTRUCTION METHODS ILLUSTRATED HERE ARE SUGGESTIONS AND APPLY ONLY TO NORMAL GROUND CONDITIONS. THERE MAY BE ADDITIONAL PRECAUTIONS AND/OR METHODS OF CONSTRUCTION. PROPER INSTALLATION IS THE RESPONSIBILITY OF THE DEALER/BUILDER/CONTRACTOR.

ITEM	FILE NAME	DESCRIPTION	CUSTOMER DRAWING #	VENDOR PART #	QTY.	VENDOR NAME	MATERIAL
1	BRACE	BRACE, 4 TAB, HYDRA - 100 SERIES	HP199	HP199	20	HYDRA POOLS	PS
2	PANEL, 6' LONG	PANEL, 6' LONG - 100 SERIES	HP106	HP106	6	HYDRA POOLS	PS
3	PANEL, 9' RADIUS WITH AQUA GENIE	PANEL, 9' RADIUS WITH AQUAGENIE - 100 SERIES	HP159A	HP159A	2	HYDRA POOLS	PS
4	PANEL, 9' RADIUS WITH LIGHT	PANEL, 9' RADIUS WITH LIGHT - 100 SERIES	HP159LL	HP159LL	1	HYDRA POOLS	PS
5	PANEL, 9' RADIUS, 4' LONG	PANEL, 9' RADIUS, 4' LONG - 100 SERIES	HP159	HP159	11	HYDRA POOLS	PS

ENGINEERING DRAWING NUMBER: 00004593	WEIGHT:	UNLESS OTHERWISE SPECIFIED DIMENSIONS ARE IN INCHES TOLERANCES DECIMALS: X ± .1 XX ± .01 XXX ± .001 XXXX ± .0005 ANGULAR: X ± 0.5 THIRD ANGLE PROJECTION	DESIGNED BY:	CREATION DATE:	HYDRA POOLS LAYOUT, 18' X 35' 9", OVAL, WEDGE BOTTOM, 6" DEEP, 100 SERIES
	VOLUME:		RCOLBOCH	7/15/2013	
	Inch ³		DETAILED BY:	DETAILED DATE:	
	COLOR:		JBOSSERDET	10/5/2012	
	HEAT TREAT:		LAST REVISED BY:	LAST REVISED DATE:	
FINISH:	jbosserdet	1/9/2015	TITLE:		
TEXTURE:	MATERIAL:		PART NUMBER:	10321	SCALE: 1:128
					SIZE: A

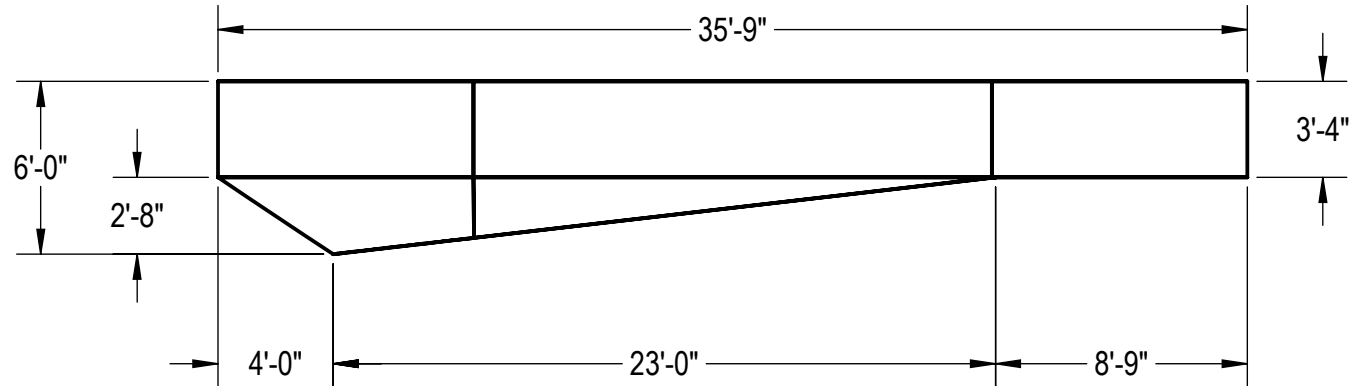
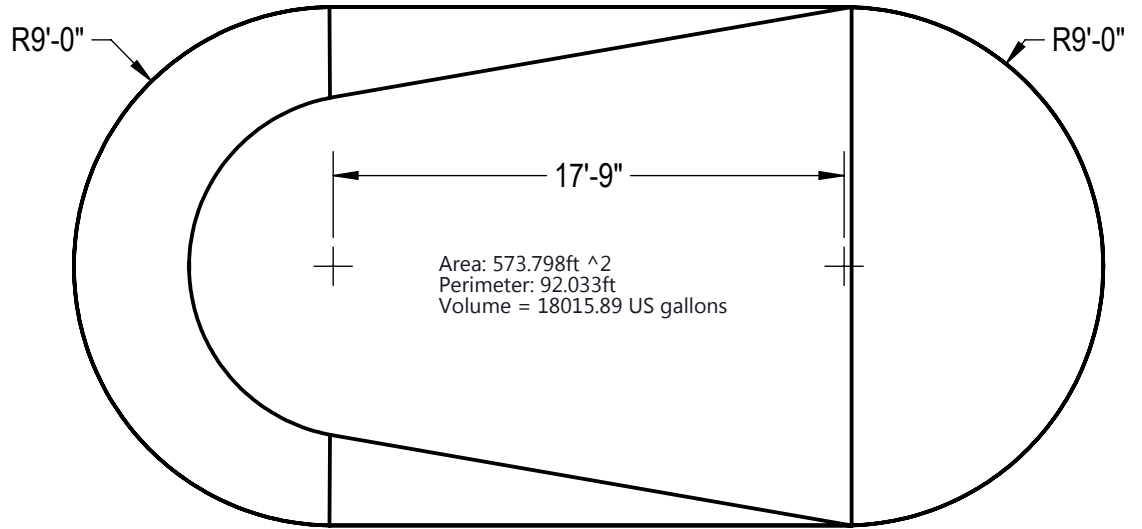
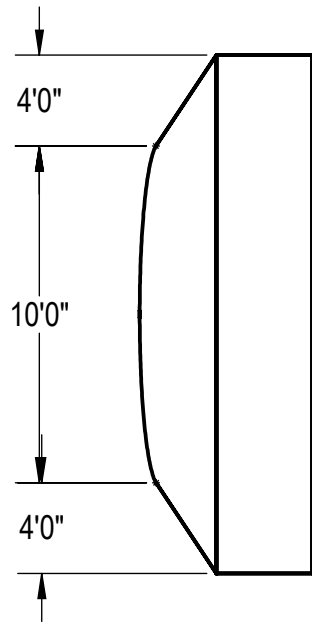

NOTES:

1. THESE ARE FINISHED DIMENSIONS READY FOR THE LINER.
2. DIMENSIONS ARE FROM INSIDE POOL PANELS.
3. THE IDEAL WATER LEVEL SHOULD BE TO THE MIDDLE OF THE SKIMMER OPENING(S).

EXCAVATION NOTES:

4. ROUGH EXCAVATION SHOULD BE 2" DEEPER IN EACH INSTANCE.
5. SOIL TO HAVE MINIMUM BEARING CAPACITY OF 1500 PSF.
6. LOCATE TOP OF POOL AT LEAST 6" ABOVE THE SURROUNDING LAND ELEVATION.
7. SEE "OVER DIG DETAIL" FOR EXCAVATION AROUND POOL.
8. FILL VOIDS UNDER BASE OF PANELS AND TAMP WELL.
9. BACK FILL WITH NON-EXPANSIVE MATERIAL.
10. ANSI / APSP / ICC-5 FOR RESIDENTIAL POOLS, 2003-2007 BOCA CODE SECTION 421.

IMPORTANT NOTES:

11. THIS DOCUMENT IS FOR ILLUSTRATIVE PURPOSES ONLY. THE DEALER OR CONTRACTOR WHO SELLS OR INSTALLS YOUR POOL IS AN INDEPENDENT CONTRACTOR AND IS NOT AN AGENT OF THE MANUFACTURER. THE CONSTRUCTION METHODS ILLUSTRATED HERE ARE SUGGESTIONS AND APPLY ONLY TO NORMAL GROUND CONDITIONS. THERE MAY BE ADDITIONAL PRECAUTIONS AND/OR METHODS OF CONSTRUCTION. PROPER INSTALLATION IS THE RESPONSIBILITY OF THE DEALER/BUILDER/CONTRACTOR.

ENGINEERING DRAWING NUMBER: 00004593	WEIGHT:	UNLESS OTHERWISE SPECIFIED DIMENSIONS ARE IN INCHES TOLERANCES DECIMALS: X ± .1 XX ± .01 XXX ± .001 XXXX ± .0005 ANGULAR: X ± 0.5 THIRD ANGLE PROJECTION 	DESIGNED BY:	CREATION DATE:	HYDRA POOLS	
	lbs		RCOLBOCH	7/15/2013		
	VOLUME:		Detailed by:	Detailed Date:	TITLE: LAYOUT, 18' X 35' 9", OVAL, WEDGE BOTTOM, 6' DEEP, 100 SERIES	
	Inch ³		JBOSSERDET	10/5/2012		
COLOR:	LAST REVISED BY:	LAST REVISED DATE:	PART NUMBER: 10321		SCALE:	SIZE:
NA	jbosserdet	1/9/2015			1:128	A
HEAT TREAT:	MATERIAL:			SHEET:	2 OF 2	
NA						
FINISH:						
NA						
TEXTURE:						
NA						