

REVISION HISTORY				
REV.	DESCRIPTION	DATE	ECO	BY
A	RELEASED FOR QUOTE	11/14/2013	NONE	RCOLBOCH
B	UPDATED TAG DATA TO INCLUDE COPING LENGTHS.	1/8/2015	391702	JBOSSERDET

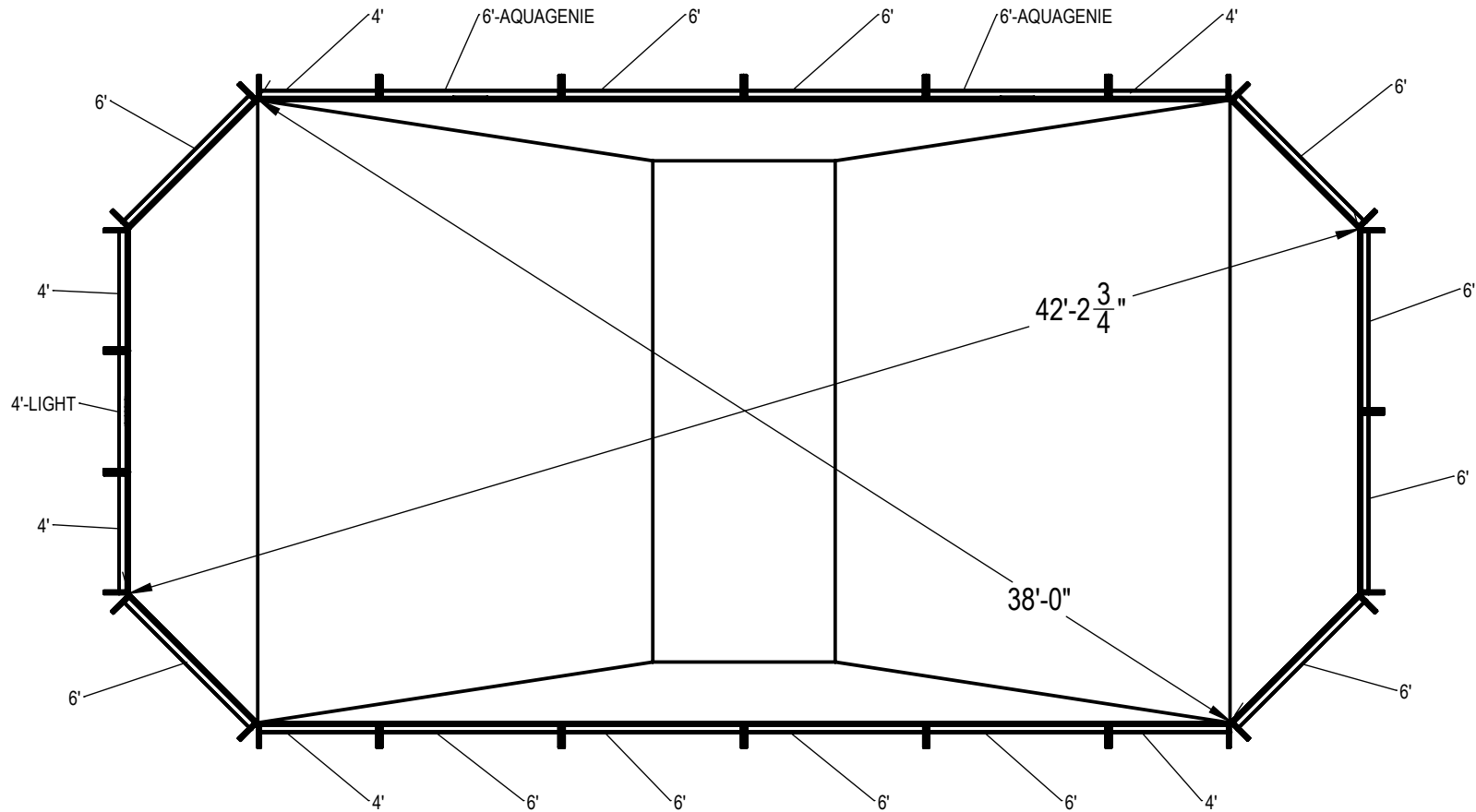

**NOTES:**

- THESE ARE FINISHED DIMENSIONS READY FOR THE LINER.
- DIMENSIONS ARE FROM INSIDE POOL PANELS.
- THE IDEAL WATER LEVEL SHOULD BE TO THE MIDDLE OF THE SKIMMER OPENING(S).

**EXCAVATION NOTES:**

- ROUGH EXCAVATION SHOULD BE 2" DEEPER IN EACH INSTANCE.
- SOIL TO HAVE MINIMUM BEARING CAPACITY OF 1500 PSF.
- LOCATE TOP OF POOL AT LEAST 6" ABOVE THE SURROUNDING LAND ELEVATION.
- SEE "OVER DIG DETAIL" FOR EXCAVATION AROUND POOL.
- FILL VOIDS UNDER BASE OF PANELS AND TAMP WELL.
- BACK FILL WITH NON-EXPANSIVE MATERIAL.
- ANSI / APSP / ICC-5 FOR RESIDENTIAL POOLS, 2003-2007 BOCA CODE SECTION 421.

**IMPORTANT NOTES:**

- THIS DOCUMENT IS FOR ILLUSTRATIVE PURPOSES ONLY. THE DEALER OR CONTRACTOR WHO SELLS OR INSTALLS YOUR POOL IS AN INDEPENDENT CONTRACTOR AND IS NOT AN AGENT OF THE MANUFACTURER. THE CONSTRUCTION METHODS ILLUSTRATED HERE ARE SUGGESTIONS AND APPLY ONLY TO NORMAL GROUND CONDITIONS. THERE MAY BE ADDITIONAL PRECAUTIONS AND/OR METHODS OF CONSTRUCTION. PROPER INSTALLATION IS THE RESPONSIBILITY OF THE DEALER/BUILDER/CONTRACTOR.

ITEM	FILE NAME	DESCRIPTION	CUSTOMER DRAWING #	VENDOR PART #	QTY.	VENDOR NAME	MATERIAL
1	BRACE	BRACE, 4 TAB, HYDRA - 100 SERIES	HP199	HP199	21	HYDRA POOLS	PS
2	PANEL, 4' LONG	PANEL, 4' LONG - 100 SERIES	HP104	HP104	6	HYDRA POOLS	PS
3	PANEL, 4' LONG WITH LIGHT	PANEL, 4' LONG WITH LIGHT - 100 SERIES	HP104L	HP104L	1	HYDRA POOLS	PS
4	PANEL, 6' LONG	PANEL, 6' LONG - 100 SERIES	HP106	HP106	12	HYDRA POOLS	PS
5	PANEL, 6' LONG WITH AQUA GENIE	PANEL, 6' LONG WITH AQUA GENIE - 100 SERIES	HP106A	HP106A	2	HYDRA POOLS	PS
6	BRACE, STEEL CORNER, 45° HYDRA	WEDGE, POLYMER CORNER, 45° HYDRA	HP213	HP213	8	HYDRA POOLS	G-235, 14 GA, CS-B

ENGINEERING DRAWING NUMBER: <b>00004546</b>	WEIGHT:	<b>UNLESS OTHERWISE SPECIFIED</b> DIMENSIONS ARE IN INCHES TOLERANCES DECIMALS: X ± .1 XX ± .01 XXX ± .001 XXXX ± .0005  ANGULAR: X ± 0.5 THIRD ANGLE PROJECTION	DESIGNED BY:	CREATION DATE:	<b>HYDRA POOLS</b>  <b>LAYOUT, 20'-6" X 40'-6", SPORT BOTTOM, GRECIAN, 6' DEEP, 100 SERIES</b>	
	VOLUME: Inch <sup>3</sup>		RCOLBOCH	5/29/2013		
	COLOR:		DETAILED BY:	DETAILED DATE:		
	HEAT TREAT:		JBOSSERDET	10/5/2012		
FINISH:	LAST REVISED BY:	LAST REVISED DATE:	TITLE:	PART NUMBER: <b>10243</b>	SCALE: 1:128	SIZE: <b>A</b>
TEXTURE:	Jbosserdet	1/8/2015	SHEET: 1 OF 2			

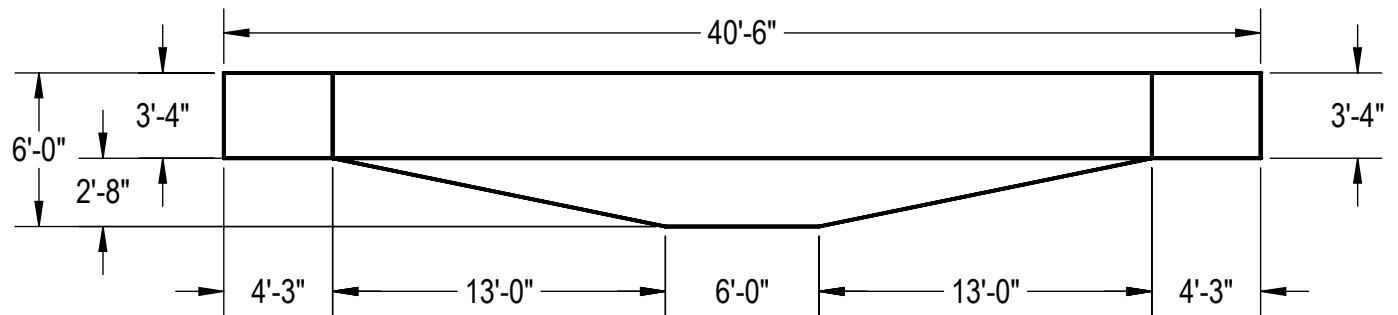
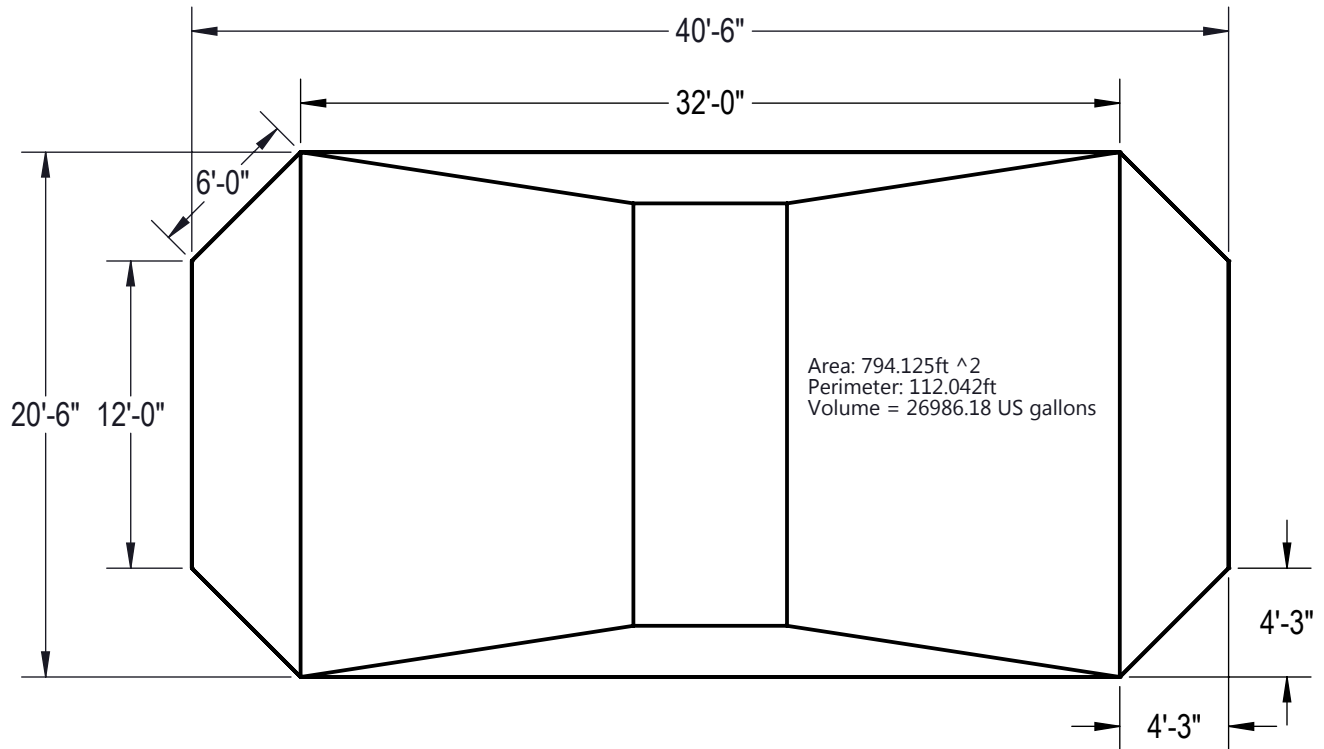
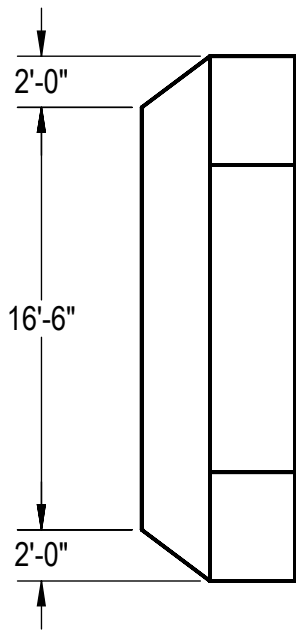

**NOTES:**

1. THESE ARE FINISHED DIMENSIONS READY FOR THE LINER.
  2. DIMENSIONS ARE FROM INSIDE POOL PANELS.
  3. THE IDEAL WATER LEVER SHOULD BE TO THE MIDDLE OF THE SKIMMER OPENING(S).
- EXCAVATION NOTES:**
4. ROUGH EXCAVATION SHOULD BE 2" DEEPER IN EACH INSTANCE.
  5. SOIL TO HAVE MINIMUM BEARING CAPACITY OF 1500 PSF.
  6. LOCATE TOP OF POOL AT LEAST 6" ABOVE THE SURROUNDING LAND ELEVATION.
  7. SEE "OVER DIG DETAIL" FOR EXCAVATION AROUND POOL.
  8. FILL VOIDS UNDER BASE OF PANELS AND TAMP WELL.
  9. BACK FILL WITH NON-EXPANSIVE MATERIAL.
  10. ANSI / APSP / ICC-5 FOR RESIDENTIAL POOLS, 2003-2007 BOCA CODE SECTION 421.

**IMPORTANT NOTES:**

11. THIS DOCUMENT IS FOR ILLUSTRATIVE PURPOSES ONLY. THE DEALER OR CONTRACTOR WHO SELLS OR INSTALLS YOUR POOL IS AN INDEPENDENT CONTRACTOR AND IS NOT AN AGENT OF THE MANUFACTURER. THE CONSTRUCTION METHODS ILLUSTRATED HERE ARE SUGGESTIONS AND APPLY ONLY TO NORMAL GROUND CONDITIONS. THERE MAY BE ADDITIONAL PRECAUTIONS AND/OR METHODS OF CONSTRUCTION. PROPER INSTALLATION IS THE RESPONSIBILITY OF THE DEALER/BUILDER/CONTRACTOR.

ENGINEERING DRAWING NUMBER: <b>00004546</b>	WEIGHT:	<b>UNLESS OTHERWISE SPECIFIED</b> DIMENSIONS ARE IN INCHES TOLERANCES DECIMALS: X ± .1 XX ± .01 XXX ± .001 XXXX ± .0005  ANGULAR: X ± 0.5 THIRD ANGLE PROJECTION	DESIGNED BY:	CREATION DATE:	<b>HYDRA POOLS</b>		
	lbs		RCOLBOCH	4/25/2013			
	VOLUME:		MATERIAL:	DETAILED BY:	DETAILED DATE:	TITLE: <b>LAYOUT, 20'-6" X 40'-6", SPORT          BOTTOM, GRECIAN, 6' DEEP, 100          SERIES</b>	
	Inch <sup>3</sup>			JBOSSERDET	10/5/2012		
	COLOR:			LAST REVISED BY:	LAST REVISED DATE:		
NA	jbosserdet	1/8/2015					
HEAT TREAT:	NA		PART NUMBER:	<b>10243</b>			
FINISH:	NA		SCALE:			SIZE:	
TEXTURE:	NA		1:128	A			
			SHEET:	2 OF 2			