

REVISION HISTORY				
REV.	DESCRIPTION	DATE	ECO	BY
C	ADDED 2ND AQUA GENIE.	3/25/2014	MATT	JBOSSERDET
D	MOVED AQUA GENIE	05/05/14	MATT	RCOLBOCH
E	UPDATED TAG DATA TO INCLUDE COPING LENGTHS.	1/5/2015	391702	JBOSSERDET

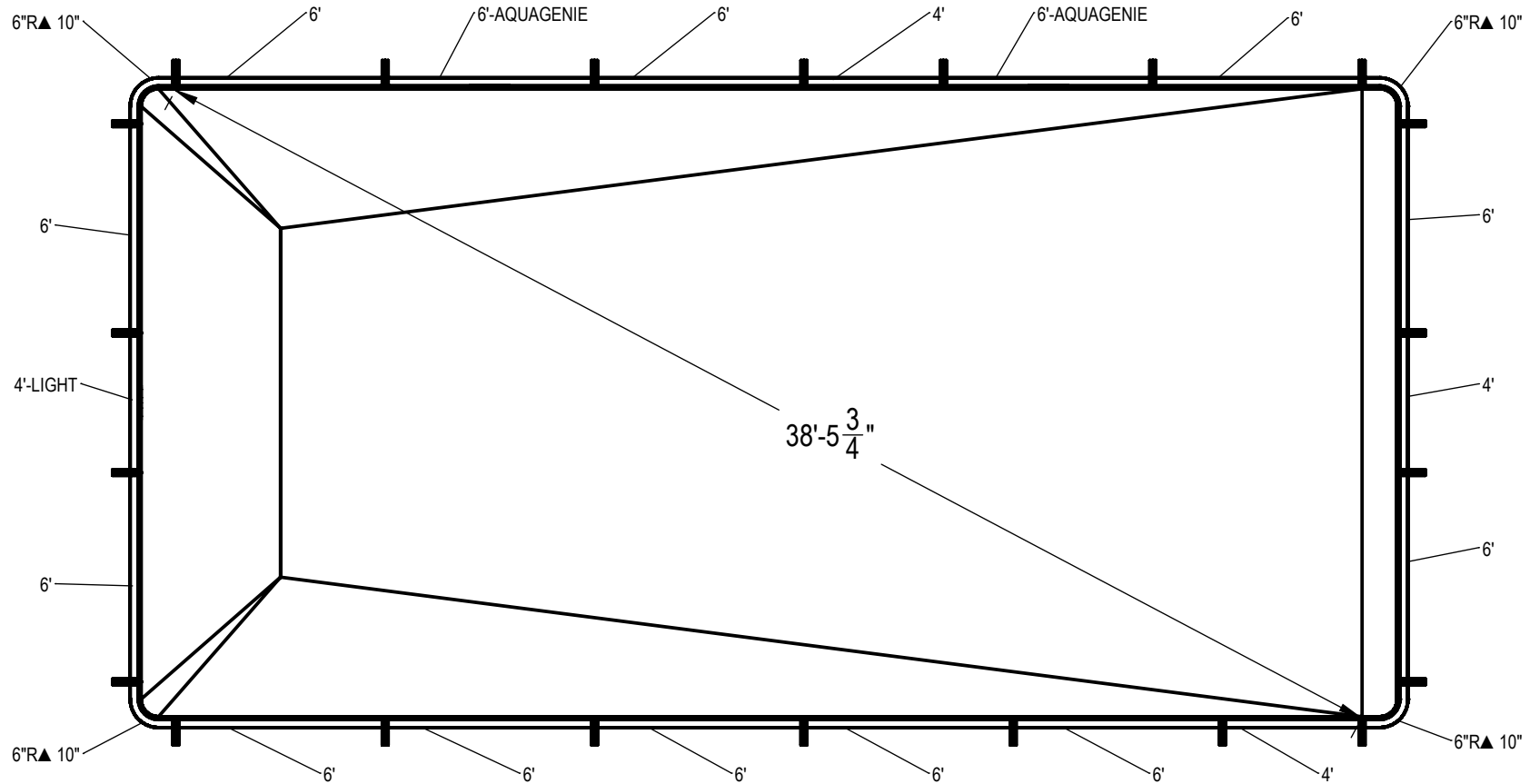

**NOTES:**

1. THESE ARE FINISHED DIMENSIONS READY FOR THE LINER.
2. DIMENSIONS ARE FROM INSIDE POOL PANELS.
3. THE IDEAL WATER LEVER SHOULD BE TO THE MIDDLE OF THE SKIMMER OPENING(S).

**EXCAVATION NOTES:**

4. ROUGH EXCAVATION SHOULD BE 2" DEEPER IN EACH INSTANCE.
5. SOIL TO HAVE MINIMUM BEARING CAPACITY OF 1500 PSF.
6. LOCATE TOP OF POOL AT LEAST 6" ABOVE THE SURROUNDING LAND ELEVATION.
7. SEE "OVER DIG DETAIL" FOR EXCAVATION AROUND POOL.
8. FILL VOIDS UNDER BASE OF PANELS AND TAMP WELL.
9. BACK FILL WITH NON-EXPANSIVE MATERIAL.
10. ANSI / APSP / ICC-5 FOR RESIDENTIAL POOLS, 2003-2007 BOCA CODE SECTION 421.

**IMPORTANT NOTES:**

11. THIS DOCUMENT IS FOR ILLUSTRATIVE PURPOSES ONLY. THE DEALER OR CONTRACTOR WHO SELLS OR INSTALLS YOUR POOL IS AN INDEPENDENT CONTRACTOR AND IS NOT AN AGENT OF THE MANUFACTURER. THE CONSTRUCTION METHODS ILLUSTRATED HERE ARE SUGGESTIONS AND APPLY ONLY TO NORMAL GROUND CONDITIONS. THERE MAY BE ADDITIONAL PRECAUTIONS AND/OR METHODS OF CONSTRUCTION. PROPER INSTALLATION IS THE RESPONSIBILITY OF THE DEALER/BUILDER/CONTRACTOR.

ITEM	FILE NAME	DESCRIPTION	CUSTOMER DRAWING #	VENDOR PART #	QTY.	VENDOR NAME	MATERIAL
1	BRACE	BRACE, 4 TAB, HYDRA - 100 SERIES	HP199	HP199	23	HYDRA POOLS	PS
2	PANEL, 4' LONG	PANEL, 4' LONG - 100 SERIES	HP104	HP104	3	HYDRA POOLS	PS
3	PANEL, 4' LONG WITH LIGHT	PANEL, 4' LONG WITH LIGHT - 100 SERIES	HP104L	HP104L	1	HYDRA POOLS	PS
4	PANEL, 6" IN RADIUS, 6" IN X 6" IN	PANEL, 6" RADIUS - 100 SERIES	HP156	HP156	4	HYDRA POOLS	PS
5	PANEL, 6' LONG	PANEL, 6' LONG - 100 SERIES	HP106	HP106	12	HYDRA POOLS	PS
6	PANEL, 6' LONG WITH AQUA GENIE	PANEL, 6' LONG WITH AQUA GENIE - 100 SERIES	HP106A	HP106A	2	HYDRA POOLS	PS

ENGINEERING DRAWING NUMBER: <b>00004296</b>	WEIGHT:	<b>UNLESS OTHERWISE SPECIFIED</b> DIMENSIONS ARE IN INCHES TOLERANCES DECIMALS: X ± .1 XX ± .01 XXX ± .001 XXXX ± .0005  ANGULAR: X ± 0.5 THIRD ANGLE PROJECTION 	DESIGNED BY:	CREATION DATE:	<b>HYDRA POOLS</b>  <b>LAYOUT, 18' X 36', RECTANGLE,          WEDGE BOTTOM, 6' DEEP, 6" RADIUS,          100 SERIES</b>
	VOLUME:		RCOLBOCH	6/3/2013	
	INCH <sup>3</sup> :		RCOLBOCH	10/5/2012	
	COLOR:		JBOSSERDET	1/5/2015	
	HEAT TREAT:		JBOSSERDET		
	FINISH:				
TEXTURE:					
PART NUMBER:		<b>10141</b>		SCALE:	SIZE:
				1:96	A
				SHEET:	
				1 OF 2	

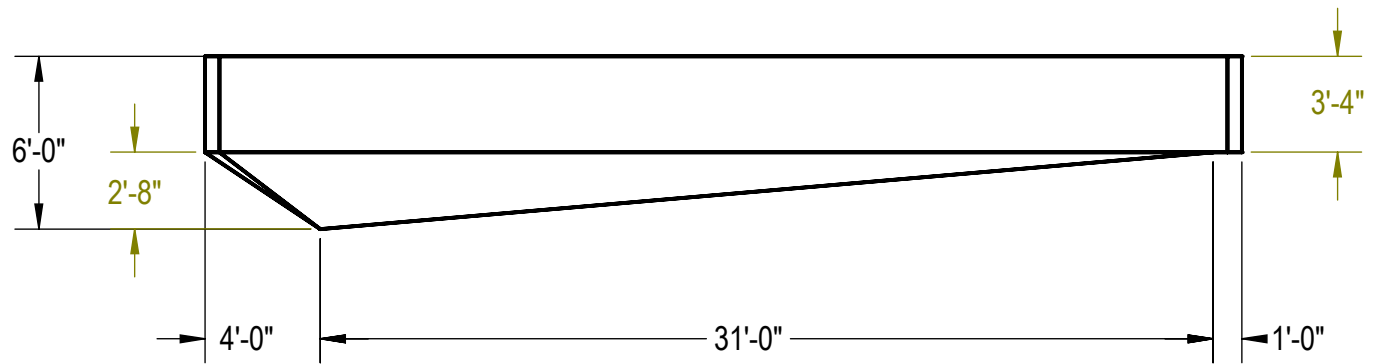
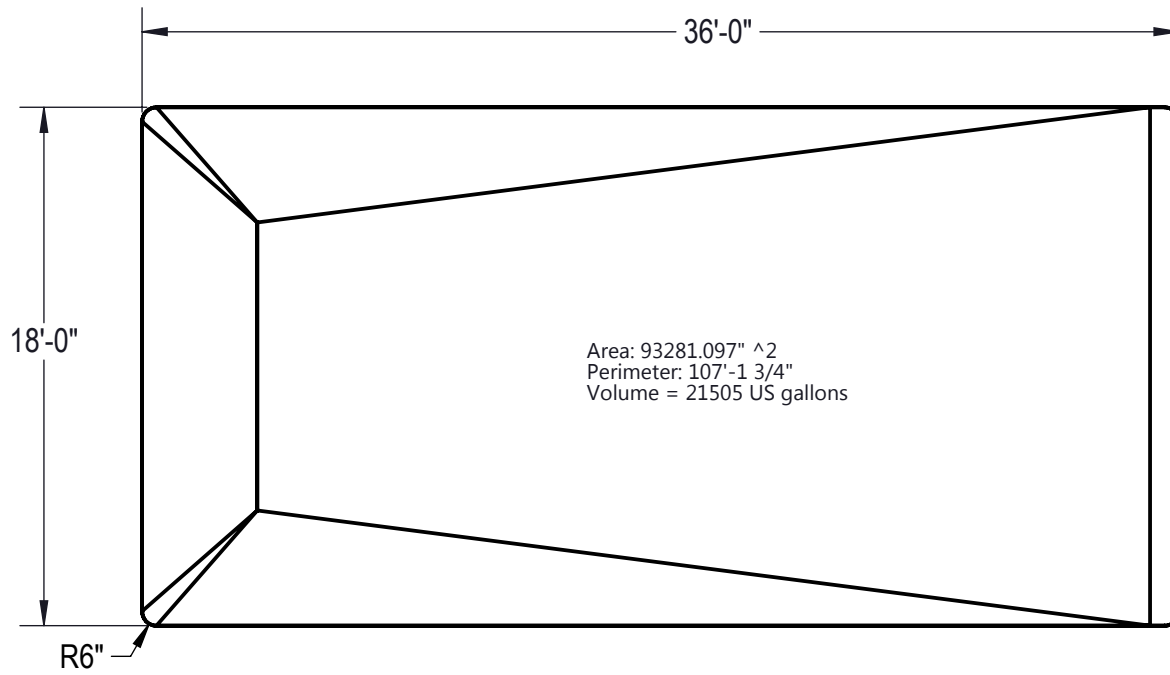
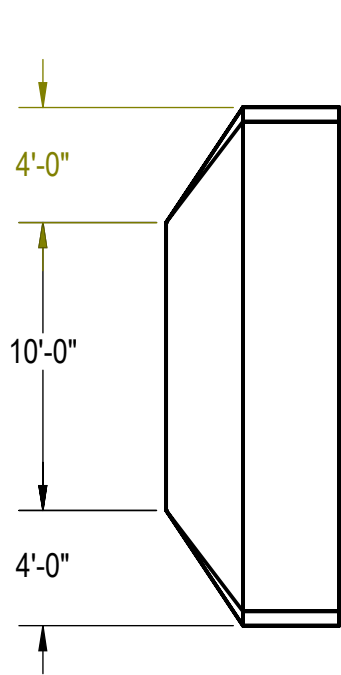

**NOTES:**

1. THESE ARE FINISHED DIMENSIONS READY FOR THE LINER.
2. DIMENSIONS ARE FROM INSIDE POOL PANELS.
3. THE IDEAL WATER LEVEL SHOULD BE TO THE MIDDLE OF THE SKIMMER OPENING(S).

**EXCAVATION NOTES:**

4. ROUGH EXCAVATION SHOULD BE 2" DEEPER IN EACH INSTANCE.
5. SOIL TO HAVE MINIMUM BEARING CAPACITY OF 1500 PSF.
6. LOCATE TOP OF POOL AT LEAST 6" ABOVE THE SURROUNDING LAND ELEVATION.
7. SEE "OVER DIG DETAIL" FOR EXCAVATION AROUND POOL.
8. FILL VOIDS UNDER BASE OF PANELS AND TAMP WELL.
9. BACK FILL WITH NON-EXPANSIVE MATERIAL.
10. ANSI / APSP / ICC-5 FOR RESIDENTIAL POOLS, 2003-2007 BOCA CODE SECTION 421.

**IMPORTANT NOTES:**

11. THIS DOCUMENT IS FOR ILLUSTRATIVE PURPOSES ONLY. THE DEALER OR CONTRACTOR WHO SELLS OR INSTALLS YOUR POOL IS AN INDEPENDENT CONTRACTOR AND IS NOT AN AGENT OF THE MANUFACTURER. THE CONSTRUCTION METHODS ILLUSTRATED HERE ARE SUGGESTIONS AND APPLY ONLY TO NORMAL GROUND CONDITIONS. THERE MAY BE ADDITIONAL PRECAUTIONS AND/OR METHODS OF CONSTRUCTION. PROPER INSTALLATION IS THE RESPONSIBILITY OF THE DEALER/BUILDER/CONTRACTOR.

ENGINEERING DRAWING NUMBER: <b>00004296</b>	WEIGHT:	<b>UNLESS OTHERWISE SPECIFIED</b> DIMENSIONS ARE IN INCHES TOLERANCES DECIMALS: X ± .1 XX ± .01 XXX ± .001 XXXX ± .0005  ANGULAR: X ± 0.5 THIRD ANGLE PROJECTION 	DESIGNED BY:	CREATION DATE:	<b>HYDRA POOLS</b>	
	lbs		rcolboch	7/31/2013		
	VOLUME:			DETAILED BY:	DETAILED DATE:	<b>LAYOUT, 18' X 36', RECTANGLE,          WEDGE BOTTOM, 6' DEEP, 6" RADIUS,          100 SERIES</b>
	Inch <sup>3</sup>			JBOSSERDET	10/5/2012	
	COLOR:			LAST REVISED BY:	LAST REVISED DATE:	
NA		jbosserset	1/5/2015	PART NUMBER:	<b>10141</b>	
HEAT TREAT:		MATERIAL:		SCALE:	1:96	
NA				SHEET:	2 OF 2	
FINISH:				SIZE:	<b>A</b>	
NA						
TEXTURE:						
NA						