

22' X 43' MARTINIQUE LEFT 4'R

REVISION HISTORY		DATE	STATUS	ECO	BY
REV.	DESCRIPTION				

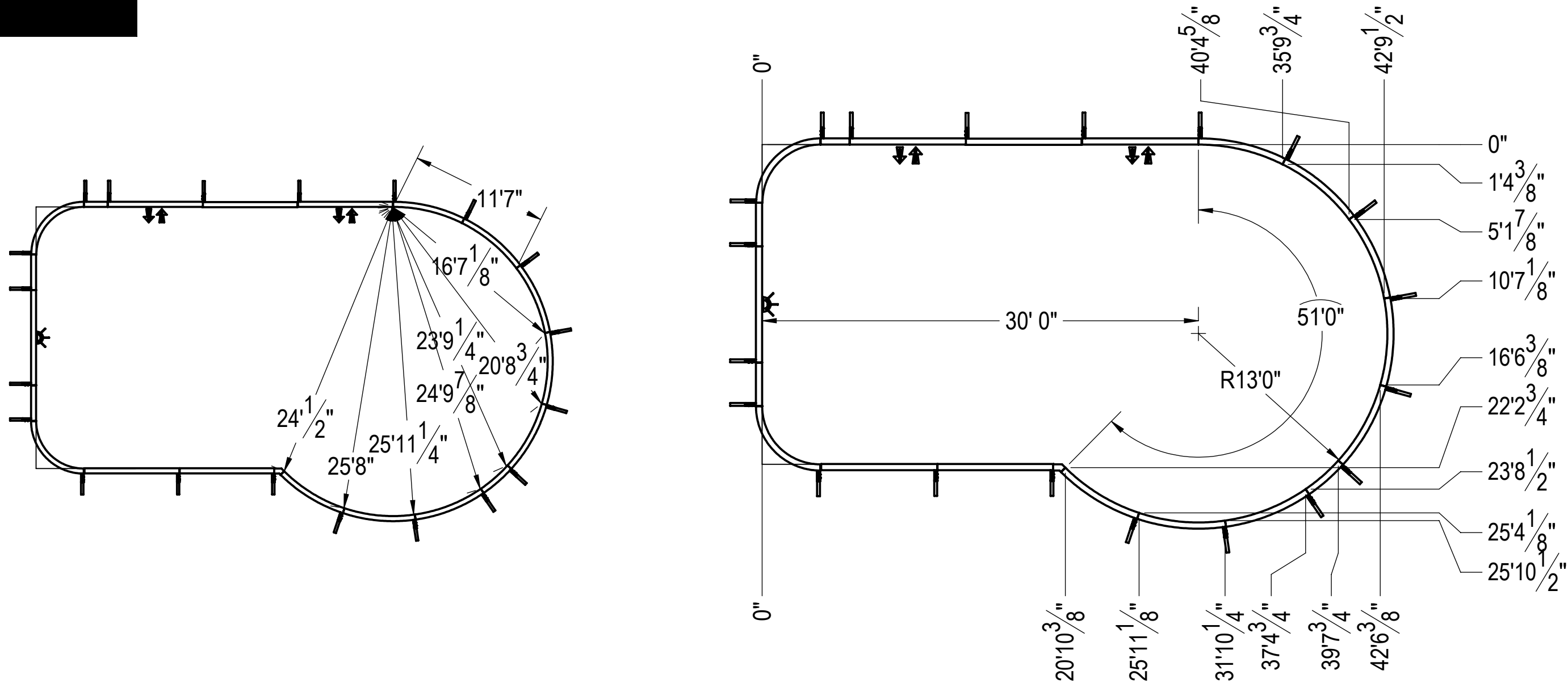

- NOTES:**
1. THESE ARE FINISHED DIMENSIONS READY FOR THE LINER.
 2. DIMENSIONS ARE FROM INSIDE POOL PANELS.
 3. THE IDEAL WATER LEVEL SHOULD BE TO THE MIDDLE OF THE SKIMMER OPENING(S).
- EXCAVATION NOTES:**
4. ROUGH EXCAVATION SHOULD BE 2" DEEPER IN EACH INSTANCE.
 5. SOIL TO HAVE MINIMUM BEARING CAPACITY OF 2000 PSF.
 6. LOCATE TOP OF POOL AT LEAST 6" ABOVE THE SURROUNDING LAND ELEVATION.
 7. SEE "OVER DIG DETAIL" FOR EXCAVATION AROUND POOL.
 8. FILL VOIDS UNDER BASE OF PANELS AND TAMP WELL.
 9. BACK FILL WITH NON-EXPANSIVE MATERIAL.

IMPORTANT NOTES:
 THIS DOCUMENT IS FOR ILLUSTRATIVE PURPOSES ONLY. THE DEALER OR CONTRACTOR WHO SELLS OR INSTALLS YOUR POOL IS AN INDEPENDENT CONTRACTOR AND IS NOT AN AGENT OF THE MANUFACTURER. THE CONSTRUCTION METHODS ILLUSTRATED HERE ARE SUGGESTIONS AND APPLY ONLY TO NORMAL GROUND CONDITIONS. THERE MAY BE ADDITIONAL PRECAUTIONS AND/OR METHODS OF CONSTRUCTION. PROPER INSTALLATION IS THE RESPONSIBILITY OF THE DEALER/BUILDER/CONTRACTOR.

PANEL LEGEND



NO DIVING WARNING:
ATTENTION DEALER/BUILDER:
 It is your responsibility to ensure the safety package provided is delivered to the pool owner and that the "NO DIVING" labels are properly installed.



"NO DIVING" WARNING LABELS MUST BE INSTALLED IN NO DIVING AREAS ACCORDING TO ANSI SPECIFICATIONS

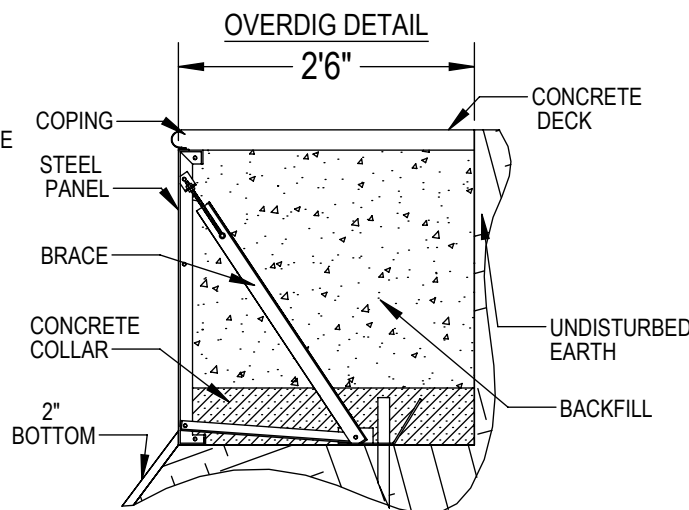

ENGINEERING DRAWING NUMBER: 00000868	WEIGHT: 86.515 lbs	UNLESS OTHERWISE SPECIFIED DIMENSIONS ARE IN INCHES	DESIGNED BY: RCOLBOCH	CREATION DATE: 10/17/2012	TITLE: SAMSON STEEL BY HYDRA POOLS 22' X 43' MARTINIQUE LEFT 4'R
	VOLUME: 2394.720 Inch ³		TOLERANCES DECIMALS: X ± 0.1 XX ± 0.01 XXX ± 0.005 XXXX ± 0.0005	DETAILED BY: Rcolboch	
	COLOR: NA	ANGULAR: X ± 0.5 THIRD ANGLE PROJECTION	LAST REVISED BY: rcolboch	LAST REVISED DATE: 11/14/2012	
	HEAT TREAT: NA		MATERIAL: Material <not specified>		
FINISH: NA					PART NUMBER: 60396A
TEXTURE: NA					SCALE: 1:96 SHEET: 1 OF 1

SIZE:
B