

20' X 39'7" FIGURE-8

REVISION HISTORY		DATE	STATUS	ECO	BY
REV.	DESCRIPTION				

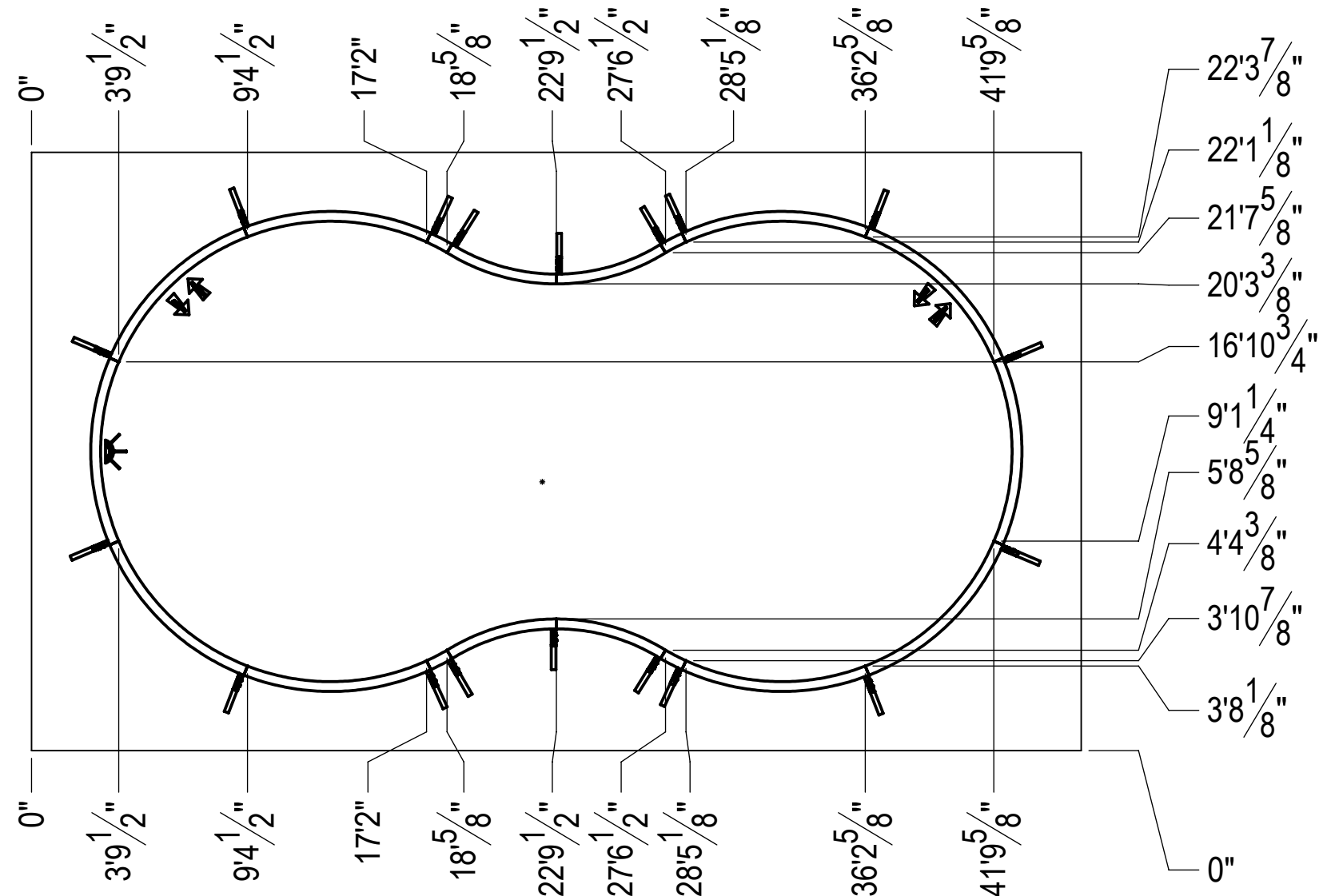
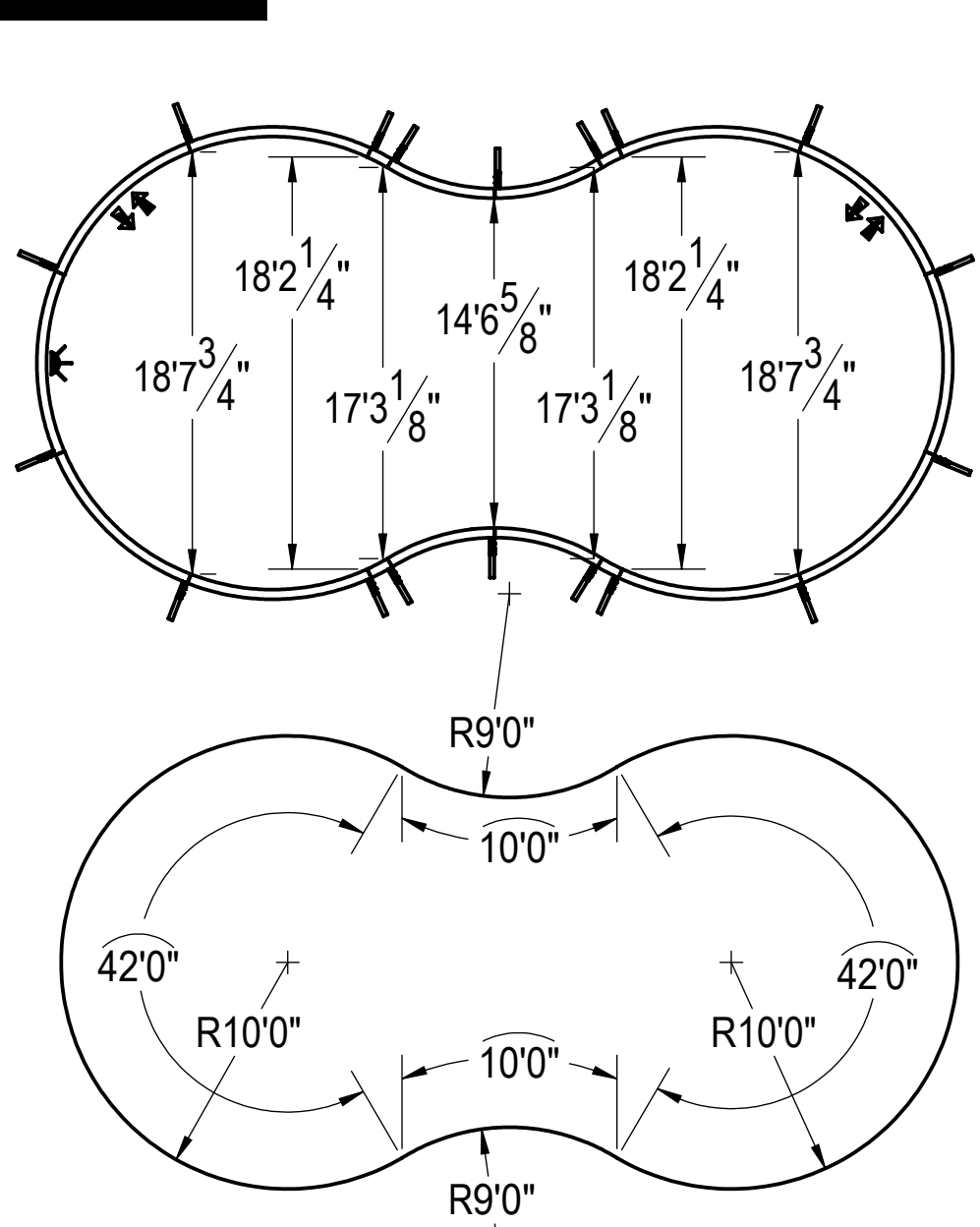

NOTES:

1. THESE ARE FINISHED DIMENSIONS READY FOR THE LINER.
2. DIMENSIONS ARE FROM INSIDE POOL PANELS.
3. THE IDEAL WATER LEVEL SHOULD BE TO THE MIDDLE OF THE SKIMMER OPENING(S).

EXCAVATION NOTES:

4. ROUGH EXCAVATION SHOULD BE 2" DEEPER IN EACH INSTANCE.
5. SOIL TO HAVE MINIMUM BEARING CAPACITY OF 2000 PSF.
6. LOCATE TOP OF POOL AT LEAST 6" ABOVE THE SURROUNDING LAND ELEVATION.
7. SEE "OVER DIG DETAIL" FOR EXCAVATION AROUND POOL.
8. FILL VOIDS UNDER BASE OF PANELS AND TAMP WELL.
9. BACK FILL WITH NON-EXPANSIVE MATERIAL.

IMPORTANT NOTES:
THIS DOCUMENT IS FOR ILLUSTRATIVE PURPOSES ONLY. THE DEALER OR CONTRACTOR WHO SELLS OR INSTALLS YOUR POOL IS AN INDEPENDENT CONTRACTOR AND IS NOT AN AGENT OF THE MANUFACTURER. THE CONSTRUCTION METHODS ILLUSTRATED HERE ARE SUGGESTIONS AND APPLY ONLY TO NORMAL GROUND CONDITIONS. THERE MAY BE ADDITIONAL PRECAUTIONS AND/OR METHODS OF CONSTRUCTION. PROPER INSTALLATION IS THE RESPONSIBILITY OF THE DEALER/BUILDER/CONTRACTOR.

PANEL LEGEND

LIGHT
 SKIMMER
 AQUAGENIE

NO DIVING WARNING:
ATTENTION DEALER/BUILDER:
It is your responsibility to ensure the safety package provided is delivered to the pool owner and that the "NO DIVING" labels are properly installed.

NO DIVING WARNING LABELS MUST BE INSTALLED IN NO DIVING AREAS ACCORDING TO ANSI SPECIFICATIONS

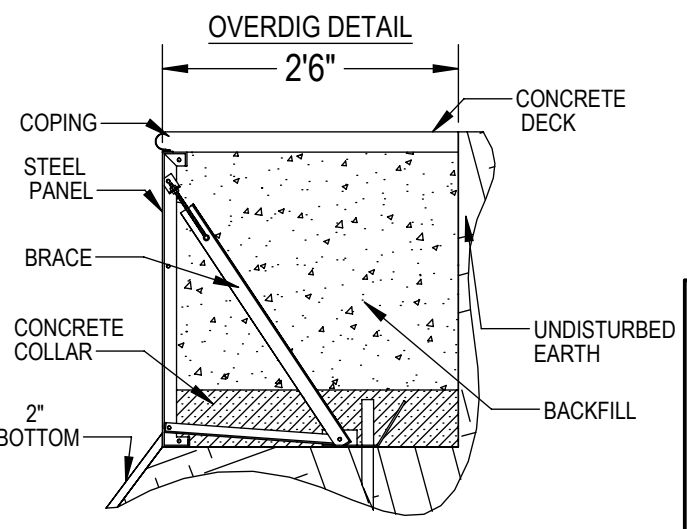

WEIGHT: 86,515 lbs VOLUME: 2394.720 Inch ³ COLOR: NA HEAT TREAT: NA FINISH: NA TEXTURE: NA	UNLESS OTHERWISE SPECIFIED DIMENSIONS ARE IN INCHES TOLERANCES DECIMALS: X ± 0.1 XX ± 0.01 XXX ± 0.005 XXXX ± 0.0005 ANGULAR: X ± 0.5 THIRD ANGLE PROJECTION	DESIGNED BY: RCOLBOCH DETAILED BY: Rcolboch LAST REVISED BY: rcolboch MATERIAL: Material <not specified>	CREATION DATE: 10/17/2012 DETAILED DATE: 8/30/2012 LAST REVISED DATE: 11/14/2012	TITLE: SAMSON STEEL BY HYDRA POOLS 20' X 39'7" FIGURE-8
	ENGINEERING DRAWING NUMBER: 00000870	PART NUMBER: 60401	SCALE: 1:96 SHEET: 1 OF 1	SIZE: B

97A