

18' X 33'7" KIDNEY RIGHT

REVISION HISTORY					
REV.	DESCRIPTION	DATE	STATUS	ECO	BY

DIMENSIONS	SQ FOOT	624	PERIMETER	88'	GALLONS	17912
------------	---------	-----	-----------	-----	---------	-------

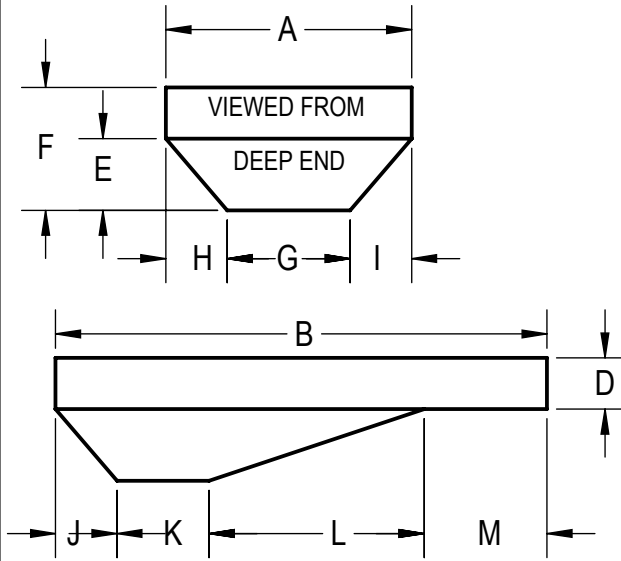

A	18'	K	6'0"
B	34'-4 1/2"	L	14'0"
D	3'4"	M	10'4 1/2"
E	4'-8"	M2	
F	8'0"	T	
G	10'0"	S	
H	4'0"	N	
I	4'0"	P	
J	4'0"	U	

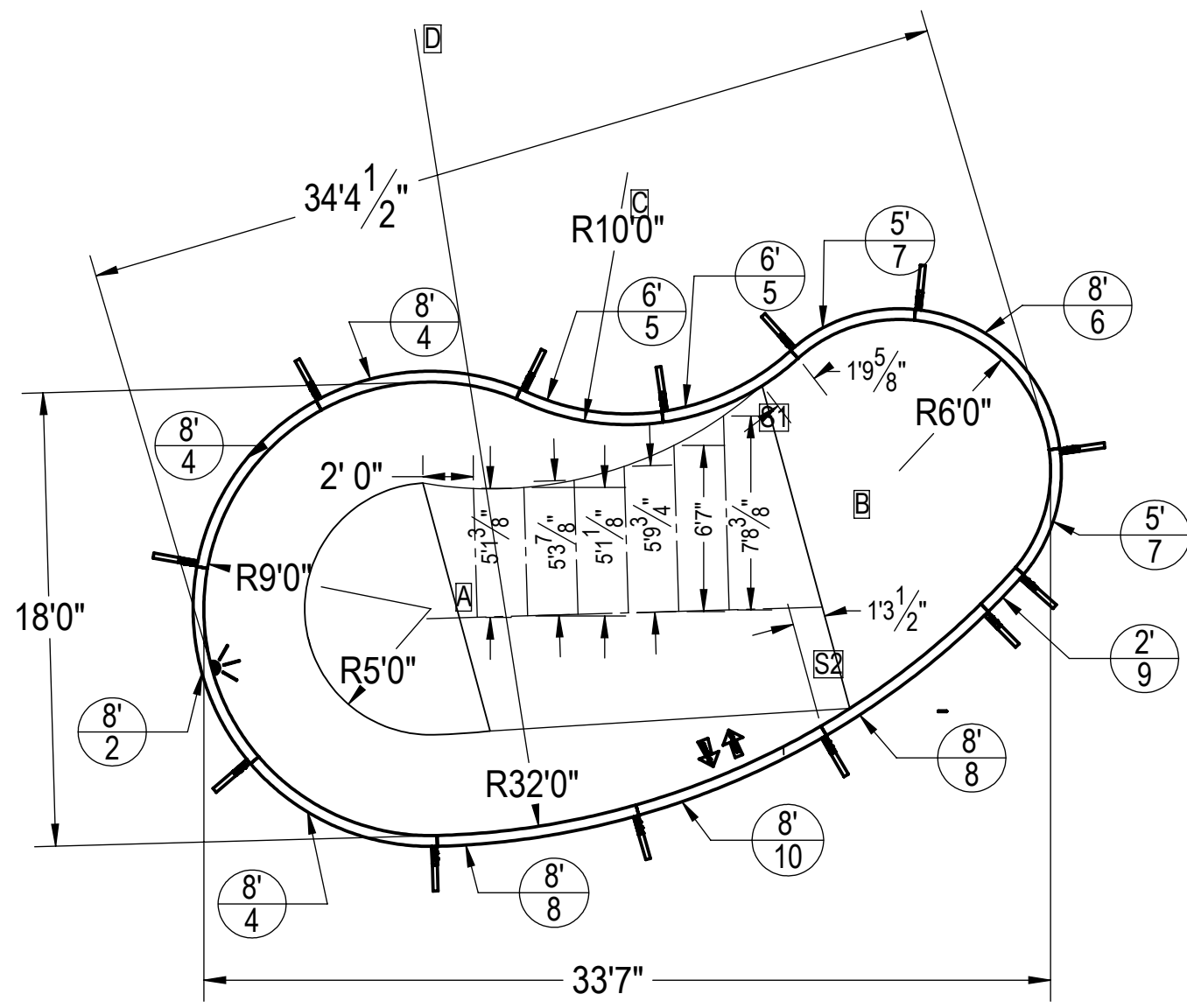

A-B	19'-4 1/2"
A-C	18'-11 7/8"
A-D	22'-11 7/8"
B-C	16'-0"
B-D	26'-0"
A-S1	15'-10 1/4"
A-S2	17'-1"
B-S1	6'-5"
B-S2	9'-7 5/8"

NOTES:
 1. THESE ARE FINISHED DIMENSIONS READY FOR THE LINER.
 2. DIMENSIONS ARE FROM INSIDE POOL PANELS.
 3. THE IDEAL WATER LEVEL SHOULD BE TO THE MIDDLE OF THE SKIMMER OPENING(S).

EXCAVATION NOTES:
 4. ROUGH EXCAVATION SHOULD BE 2" DEEPER IN EACH INSTANCE.
 5. SOIL TO HAVE MINIMUM BEARING CAPACITY OF 2000 PSF.
 6. LOCATE TOP OF POOL AT LEAST 6" ABOVE THE SURROUNDING LAND ELEVATION.
 7. SEE "OVER DIG DETAIL" FOR EXCAVATION AROUND POOL.
 8. FILL VOIDS UNDER BASE OF PANELS AND TAMP WELL.
 9. BACK FILL WITH NON-EXPANSIVE MATERIAL.

IMPORTANT NOTES:
 THIS DOCUMENT IS FOR ILLUSTRATIVE PURPOSES ONLY. THE DEALER OR CONTRACTOR WHO SELLS OR INSTALLS YOUR POOL IS AN INDEPENDENT CONTRACTOR AND IS NOT AN AGENT OF THE MANUFACTURER. THE CONSTRUCTION METHODS ILLUSTRATED HERE ARE SUGGESTIONS AND APPLY ONLY TO NORMAL GROUND CONDITIONS. THERE MAY BE ADDITIONAL PRECAUTIONS AND/OR METHODS OF CONSTRUCTION. PROPER INSTALLATION IS THE RESPONSIBILITY OF THE DEALER/BUILDER/CONTRACTOR.

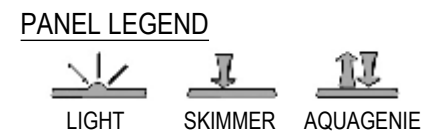

NO DIVING WARNING:
 ATTENTION DEALER/BUILDER:
 It is your responsibility to ensure the safety package provided is delivered to the pool owner and that the "NO DIVING" labels are properly installed.

"NO DIVING" WARNING LABELS MUST BE INSTALLED IN NO DIVING AREAS ACCORDING TO ANSI SPECIFICATIONS

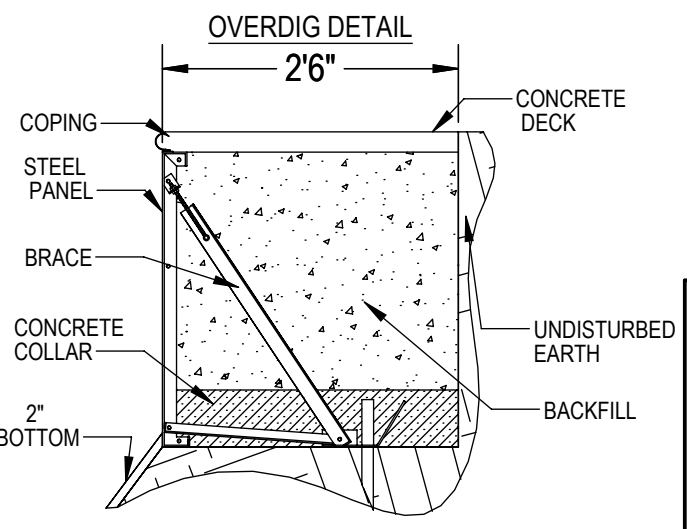

ITEM NO.	PART NUMBER	DESCRIPTION	QTY.
2	HPSD9R8L	9'R 8' LIGHT PANEL	1
3	HPSFOB	STEEL BRACE	13
4	HPSD9R8	9'R 8' PLAIN PANEL	3
5	HPSD10RR6	10'R REVERSE 6' PANEL	2
6	HPSD6R8	6'R 8' PLAIN PANEL	1
7	HPS6DR5	6'R 5' PLAIN PANEL	2
8	HPSD32R8	32'R 8' PLAIN PANEL	2
9	HPSD32R2	32'R 2' PANEL	1
10	HPSD32R8AG	32'R 8' AG PANEL	1
11	HPS1916	BOLT PACK 50 PCS	3

ENGINEERING DRAWING NUMBER: 00001211	WEIGHT: 86.515 lbs	DESIGNED BY: RCOLBOCH	CREATION DATE: 10/17/2012	SAMSON STEEL BY HYDRA POOLS 18' X 33'7" KIDNEY RIGHT PART NUMBER: 60715	
	VOLUME: 2394.720 Inch ³	DIMENSIONS ARE IN INCHES	DETAILED BY: RCOLBOCH		DETAILED DATE: 8/30/2012
	COLOR: NA	TOLERANCES DECIMALS: X ± 0.1 XX ± 0.01 XXX ± 0.005 XXXX ± 0.0005	LAST REVISED BY: RCOLBOCH		LAST REVISED DATE: 11/16/2012
	HEAT TREAT: NA	ANGULAR: X ± 0.5	MATERIAL: Material <not specified>		THIRD ANGLE PROJECTION
FINISH: NA				SCALE: 1:96	
TEXTURE: NA				SHEET: 1 OF 1	

148

18' X 33'7" KIDNEY RIGHT

REVISION HISTORY					
REV.	DESCRIPTION	DATE	STATUS	ECO	BY

	A	B	C	D	A-B	39'-6 3/8"
1	13'-3 1/8"	38'-7 1/8"	38'-10 1/4"	13'-11 5/8"	B-C	26'-5 7/8"
2	10'-1 3/8"	32'-6 1/2"	37'-6 7/8"	21'-3 7/8"	A-C	47'-7"
3	16'-6 7/8"	24'-10 7/8"	31'-6 7/8"	25'-6 1/8"		
4	22'-4 1/2"	19'-7 1/2"	26'-8 1/4"	28'-9 1/4"		
5	26'-11 1/2"	13'-8 7/8"	25'-5 7/8"	34'-5 1/2"		
6	37'-5 1/4"	8'-10 5/8"	24'-10 7/8"	39'- 1/4"		
7	37'-5 5/8"	8'-8 1/2"	18'-6 3/4"	40'-10 3/8"		
8	36'-8 1/2"	13'-6 5/8"	14'-3 7/8"	37'-9"		
9	33'-5 3/4"	15'-4 5/8"	13'-5 5/8"	35'-11 3/8"		
10	33'-5 3/4"	22'-7 3/8"	14'-1 1/2"	28'-5 3/8"		
11	30'- 1/4"	29'-6 3/8"	19'-10 1/4"	20'-6 7/8"		
12	26'-5 3/4"	35'-11 7/8"	27'-5 3/8"	12'-7 3/8"		
13	20'-11 7/8"	39'-11 1/8"	34'-10 7/8"	8'- 3/8"		

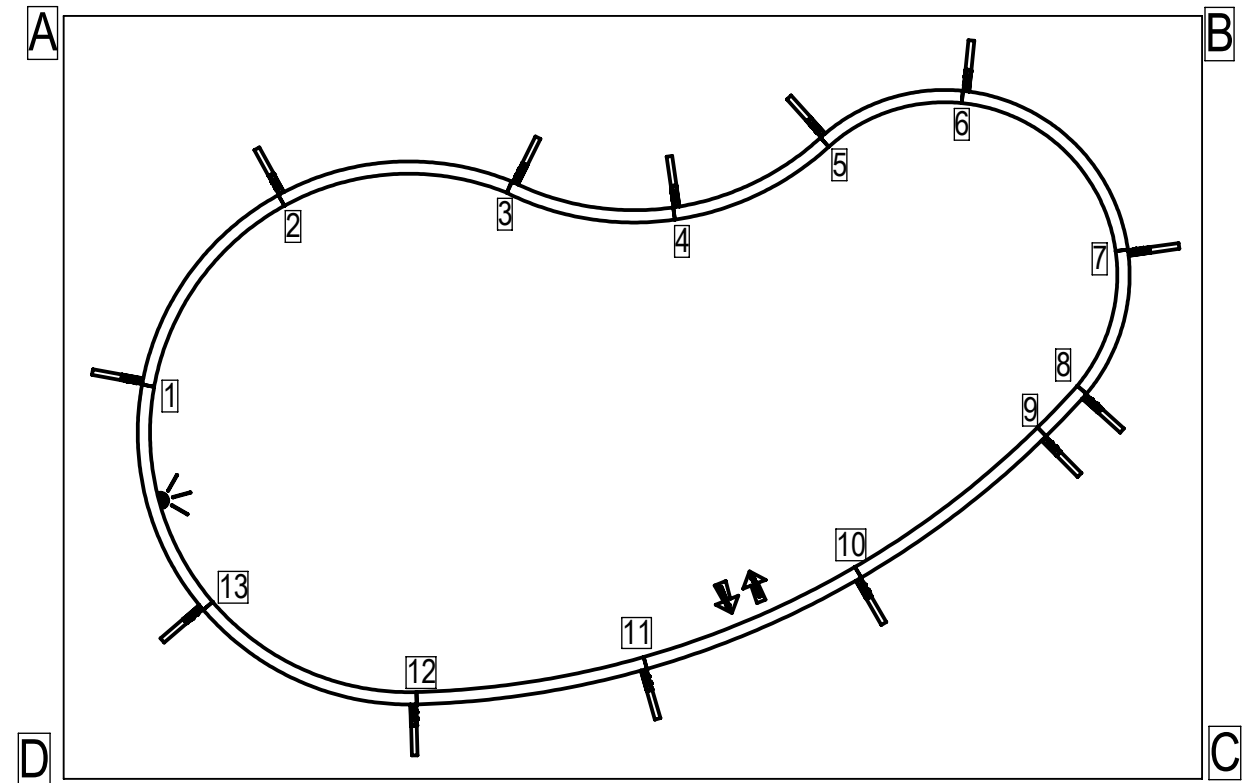

148A

NOTES:

1. THESE ARE FINISHED DIMENSIONS READY FOR THE LINER.
2. DIMENSIONS ARE FROM INSIDE POOL PANELS.
3. THE IDEAL WATER LEVEL SHOULD BE TO THE MIDDLE OF THE SKIMMER OPENING(S).

EXCAVATION NOTES:

4. ROUGH EXCAVATION SHOULD BE 2" DEEPER IN EACH INSTANCE.
5. SOIL TO HAVE MINIMUM BEARING CAPACITY OF 2000 PSF.
6. LOCATE TOP OF POOL AT LEAST 6" ABOVE THE SURROUNDING LAND ELEVATION.
7. SEE "OVER DIG DETAIL" FOR EXCAVATION AROUND POOL.
8. FILL VOIDS UNDER BASE OF PANELS AND TAMP WELL.
9. BACK FILL WITH NON-EXPANSIVE MATERIAL.

IMPORTANT NOTES:

THIS DOCUMENT IS FOR ILLUSTRATIVE PURPOSES ONLY. THE DEALER OR CONTRACTOR WHO SELLS OR INSTALLS YOUR POOL IS AN INDEPENDENT CONTRACTOR AND IS NOT AN AGENT OF THE MANUFACTURER. THE CONSTRUCTION METHODS ILLUSTRATED HERE ARE SUGGESTIONS AND APPLY ONLY TO NORMAL GROUND CONDITIONS. THERE MAY BE ADDITIONAL PRECAUTIONS AND/OR METHODS OF CONSTRUCTION. PROPER INSTALLATION IS THE RESPONSIBILITY OF THE DEALER/BUILDER/CONTRACTOR.

PANEL LEGEND



NO DIVING WARNING:
ATTENTION DEALER/BUILDER:
 It is your responsibility to ensure the safety package provided is delivered to the pool owner and that the "NO DIVING" labels are properly installed.



"NO DIVING" WARNING LABELS MUST BE INSTALLED IN NO DIVING AREAS ACCORDING TO ANSI SPECIFICATIONS

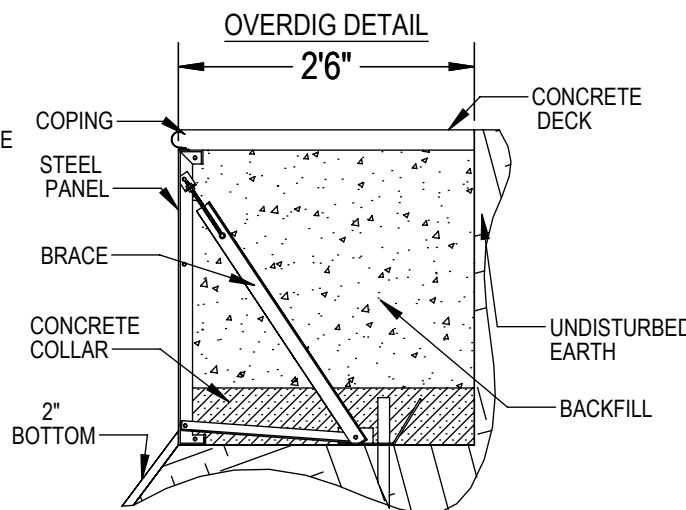

ENGINEERING DRAWING NUMBER: 000012011	WEIGHT: 86.515 lbs	UNLESS OTHERWISE SPECIFIED DIMENSIONS ARE IN INCHES TOLERANCES DECIMALS: X ± 0.1 XX ± 0.01 XXX ± 0.005 XXXX ± 0.0005	DESIGNED BY: RCOLBOCH	CREATION DATE: 10/17/2012	TITLE: SAMSON STEEL BY HYDRA POOLS 18' X 33'7" KIDNEY RIGHT
	VOLUME: 2394.720 Inch ³		DETAILED BY: Rcolboch	DETAILED DATE: 8/30/2012	
	COLOR: NA	ANGULAR: X ± 0.5 THIRD ANGLE PROJECTION	LAST REVISED BY: rcolboch	LAST REVISED DATE: 11/16/2012	
	HEAT TREAT: NA	MATERIAL: Material <not specified>	PART NUMBER: 60715-A		
FINISH: NA				SCALE: 1:96	SIZE: B
TEXTURE: NA				SHEET: 1 OF 1	

18' X 34' KIDNEY RIGHT

REVISION HISTORY					
REV.	DESCRIPTION	DATE	STATUS	ECO	BY

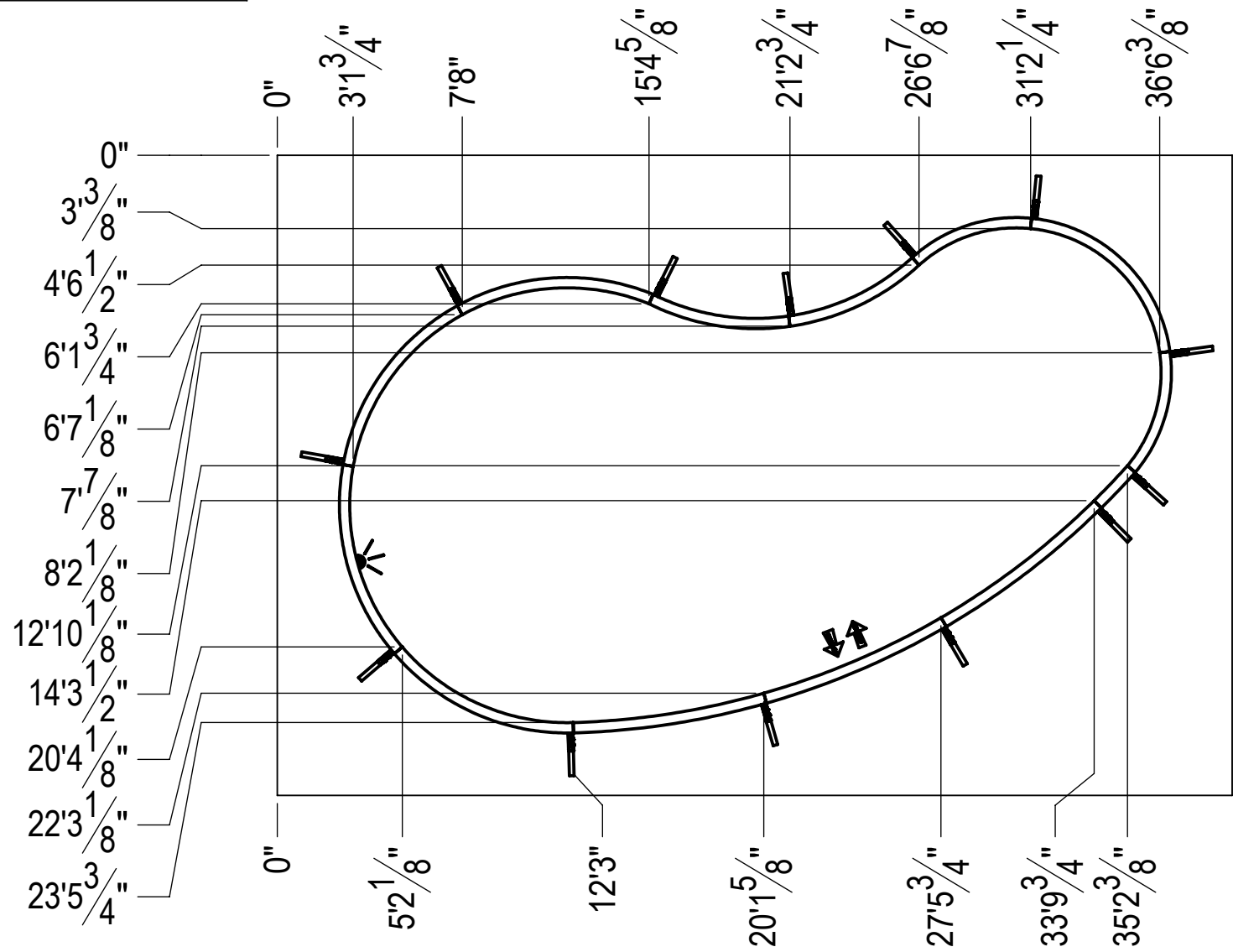
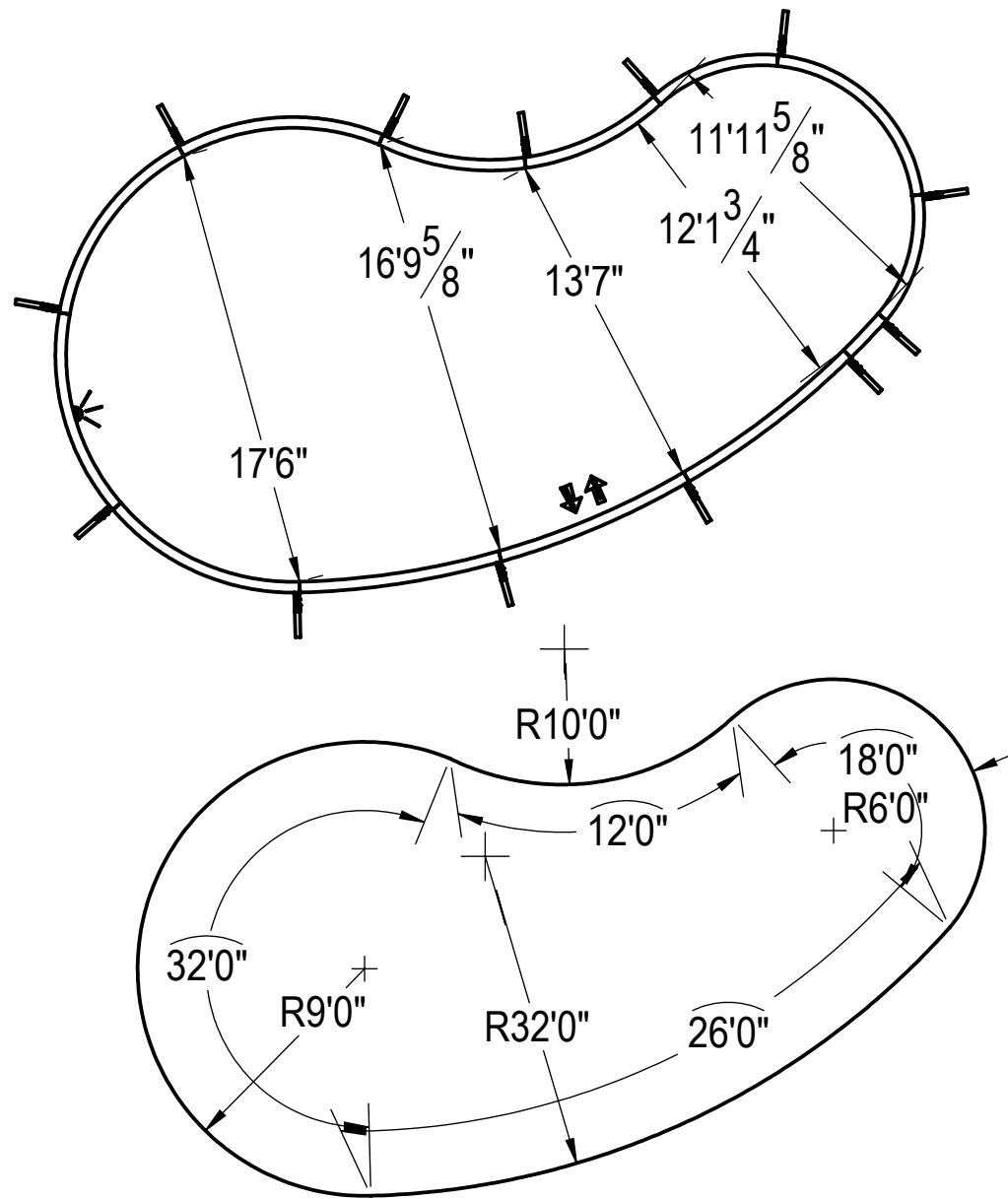

NOTES:

1. THESE ARE FINISHED DIMENSIONS READY FOR THE LINER.
2. DIMENSIONS ARE FROM INSIDE POOL PANELS.
3. THE IDEAL WATER LEVEL SHOULD BE TO THE MIDDLE OF THE SKIMMER OPENING(S).

EXCAVATION NOTES:

4. ROUGH EXCAVATION SHOULD BE 2" DEEPER IN EACH INSTANCE.
5. SOIL TO HAVE MINIMUM BEARING CAPACITY OF 2000 PSF.
6. LOCATE TOP OF POOL AT LEAST 6" ABOVE THE SURROUNDING LAND ELEVATION.
7. SEE "OVER DIG DETAIL" FOR EXCAVATION AROUND POOL.
8. FILL VOIDS UNDER BASE OF PANELS AND TAMP WELL.
9. BACK FILL WITH NON-EXPANSIVE MATERIAL.

IMPORTANT NOTES:

THIS DOCUMENT IS FOR ILLUSTRATIVE PURPOSES ONLY. THE DEALER OR CONTRACTOR WHO SELLS OR INSTALLS YOUR POOL IS AN INDEPENDENT CONTRACTOR AND IS NOT AN AGENT OF THE MANUFACTURER. THE CONSTRUCTION METHODS ILLUSTRATED HERE ARE SUGGESTIONS AND APPLY ONLY TO NORMAL GROUND CONDITIONS. THERE MAY BE ADDITIONAL PRECAUTIONS AND/OR METHODS OF CONSTRUCTION. PROPER INSTALLATION IS THE RESPONSIBILITY OF THE DEALER/BUILDER/CONTRACTOR.

PANEL LEGEND



NO DIVING WARNING:
ATTENTION DEALER/BUILDER:
 It is your responsibility to ensure the safety package provided is delivered to the pool owner and that the "NO DIVING" labels are properly installed.



"NO DIVING" WARNING LABELS MUST BE INSTALLED IN NO DIVING AREAS ACCORDING TO ANSI SPECIFICATIONS

OVERDIG DETAIL

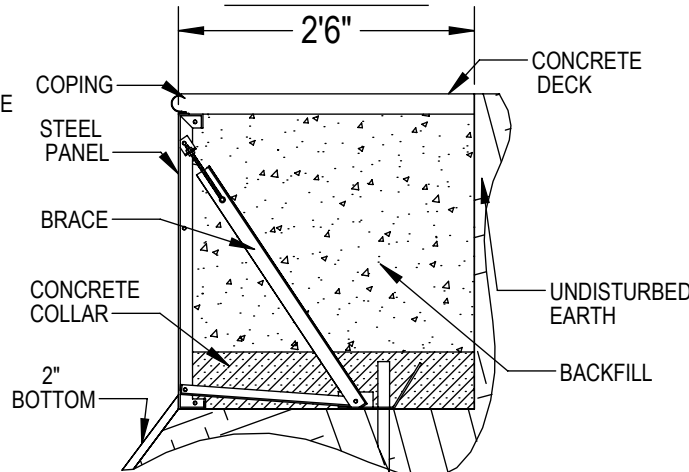

ENGINEERING DRAWING NUMBER: 00001211	WEIGHT: 86.515 lbs	UNLESS OTHERWISE SPECIFIED DIMENSIONS ARE IN INCHES TOLERANCES DECIMALS: X ± 0.1 XX ± 0.01 XXX ± 0.005 XXXX ± 0.0005	DESIGNED BY: RCOLBOCH	CREATION DATE: 10/17/2012	SAMSON STEEL BY HYDRA POOLS 18' X 34' KIDNEY RIGHT PART NUMBER: 60715-B
	VOLUME: 2394.720 Inch ³		Detailed BY: Rcolboch	DETAILED DATE: 8/30/2012	
	COLOR: NA	ANGULAR: X ± 0.5 THIRD ANGLE PROJECTION	LAST REVISED BY: rcolboch	LAST REVISED DATE: 11/16/2012	
	HEAT TREAT: NA	FINISH: NA	TEXTURE: NA	MATERIAL: Material <not specified>	
SCALE: 1:96					SIZE: B
SHEET: 1 OF 1					

148B